

Nature's Premium Greenhouse

Assembly instruction

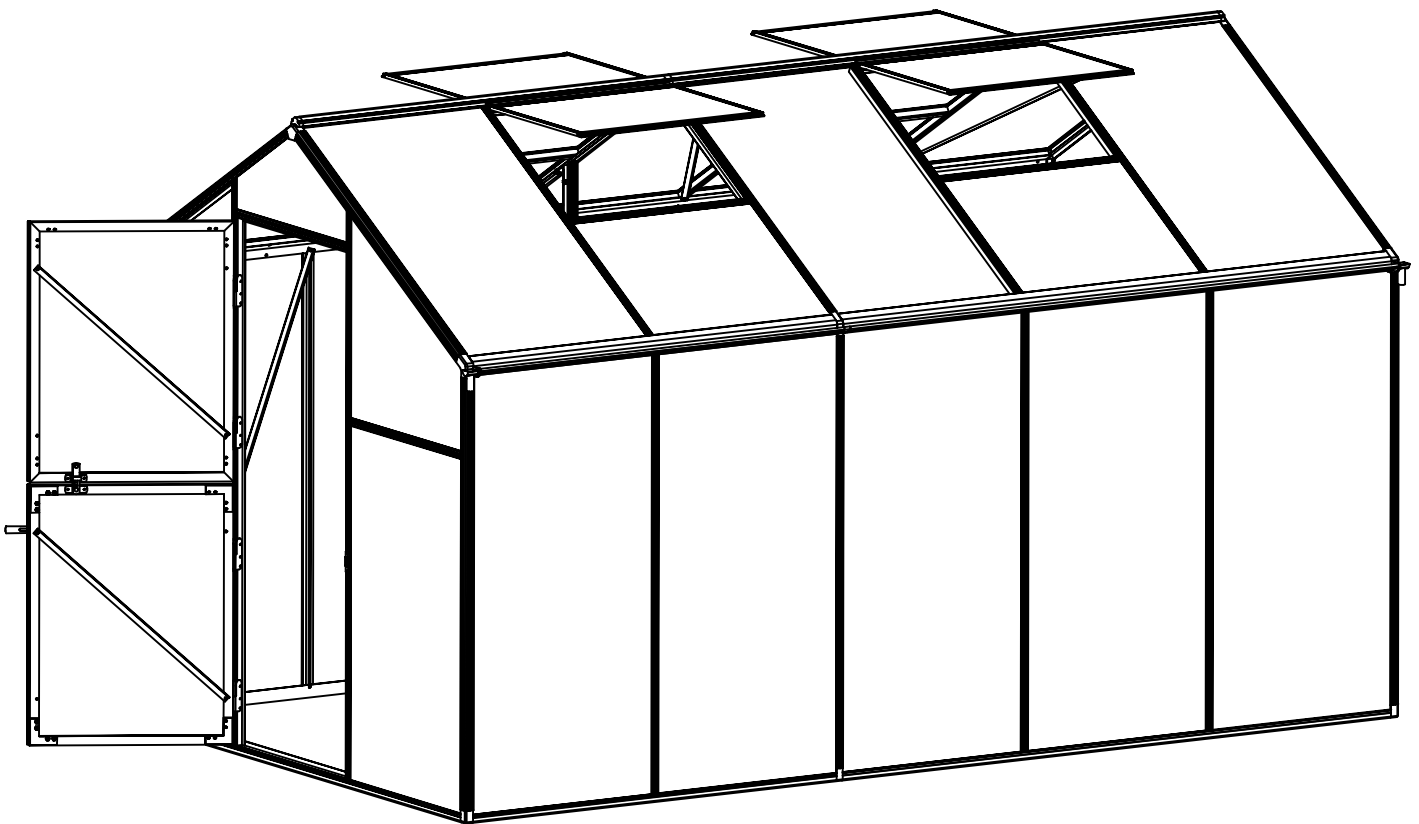

PRODUCT SIZE(LxWxH):

4 sections (2+2, size: 9'-1" x 6'-10" x 6'-10" 4mm GH),

5 sections (3+2, size: 11'-4" x 6'-10" x 6'-10" 4mm GH),

6 sections (3+3, size: 13'-7" x 6'-10" x 6'-10" 4mm GH),

PLEASE READ CAREFULLY BEFORE ASSEMBLY

Product Introduction

1. Compared to other traditional greenhouses, this product improves its aluminum profile from single layer into tube structure, which makes it much stronger and can be held more pressure.

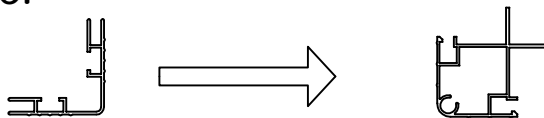

2. Easy and fast assembly.

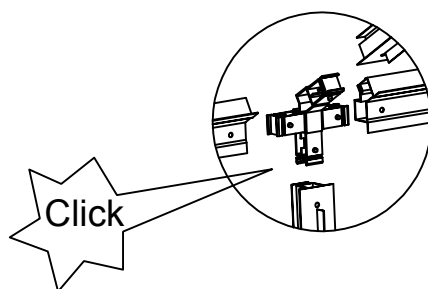

3. Can be extended with no limitation. On the basis of 2 sections and 3 sections, customers can select what they need. For example:

2 sections (size: 4'-7" x 6'-10" x 6'-10"),

3 sections (size: 6'-10" x 6'-10" x 6'-10"),

4 sections (2+2, size: 9'-1" x 6'-10" x 6'-10"),

5 sections (3+2, size: 11'-4" x 6'-10" x 6'-10"),

6 sections (3+3, size: 13'-7" x 6'-10" x 6'-10"),

7 sections (3+2+2, size: 15'-10" x 6'-10" x 6'-10"),

8 sections (3+3+2, size: 18'-1" x 6'-10" x 6'-10"),

etc.

4. To avoid any rusts, galvanized steel base is out of this product. Another two ways are available to choose. One is to use expansion screw to fix into concrete ground (default/standard); the other is to use sharp steel bar to fix into lawn land. (optional/extra charge).

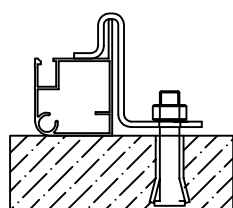

Expansion screw/Concrete ground

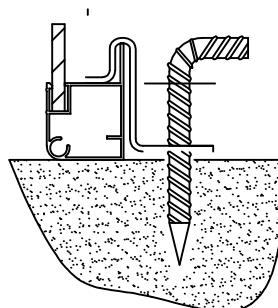

Steel bar/Lawn land

5. Convenient for transportation with no more than 2.5 meters' length of each carton box.

6. Gutter and water pipe are designed for environmental protection in this product. Rain water can be used for saving energy too.

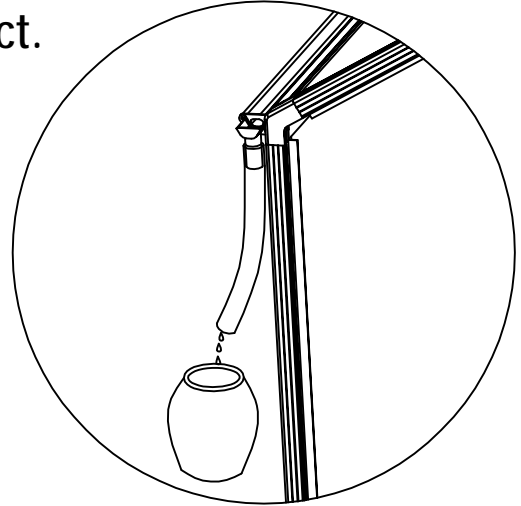

7. Two window openers are available. One is manual opener (default/standard); the other is automatic opener, item no.: JXX80001 (optional/extra charge).

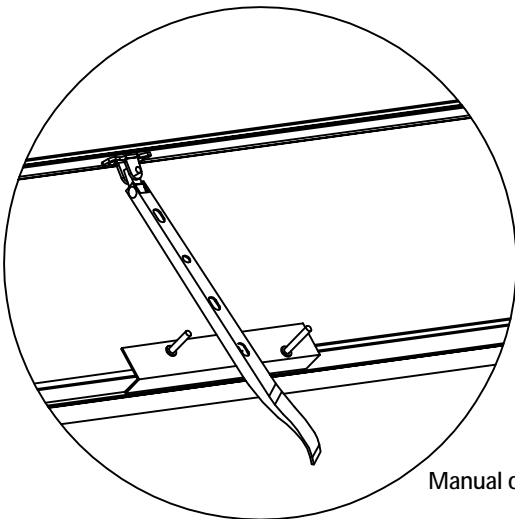



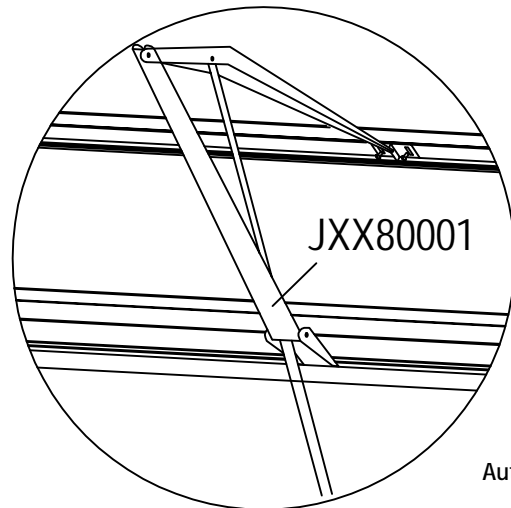









Manual opener





























Automatic opener

8. Please make sure the PC panel the side with words faces out.





























Door Assembly

PART	NO.	QTY.
	L18A	2
	L18B	2
	L17	1
	L16A	1
	L16B	1
	L16C	1
	L05G	2
	J	8
	W03	8
	S01	32
	M01	32
	Y11	2



























Back Assembly

PART	NO.	QTY.	PART	NO.	QTY.	PART	NO.	QTY.
	L01A	2		A	1		Y1	1
	L01B	1		B	1		Y2	3
	L01C	1		D	1		Y3	1
	L03C	1		E	1		Y4	1
	L03D	1		F	1			
	L04B	3		W01	2			
	L05A	2		S01	18			
	L08A	1		M01	18			
				W05	2			
				S03	2			
				J01	1			
				J02R/L	1/1			
				J03R/L	1/1			
				J07R/L	1/1			
				J08	2			



























Front Assembly

PART	NO.	QTY.	PART	NO.	QTY.	PART	NO.	QTY.
	L01A	2		A	1		Y1	1
	L01B	1		B	1		Y2	2
	L01C	1		D	1		Y5	1
	L03E	1		E	1		Y4	1
	L03F	1		F	1			
	L04B	2		W01	2			
	L04A	2		S01	18			
	L05A	2		M01	18			
	L08A	1		W05	2			
				S03	2			
				J01	1			
				J02R/L	1/1			
				J03R/L	1/1			
				J07R/L	1/1			
				J08	2			

















2 Sections Assembly Instruction













PART	NO.	QTY.	PART	NO.	QTY.	PART	NO.	QTY.
	L02A	2		W06	2		Y6	4
	L02B	2		W08	2		Y7	2
	L06	1		W04	2		Y9	2
	L07	2		S01	22		Y10	2
	L08C	2		M01	22			
	L09	2		Z01	12			
	L05C	2		Z02	6			
	L05D	2		Z03	4			
	L15A	2		W05	4			
	L19	4		S03	4			
	L20	2						
	L21	2						

3 Sections Assembly Instruction

PART	NO.	QTY.	PART	NO.	QTY.	PART	NO.	QTY.
	L02A	4		W06	2		Y6	6
	L02B	4		W08	2		Y7	4
	L06A	1		W04	4		Y9	2
	L07A	2		S01	36		Y10	2
	L08D	2		M01	36			
	L09A	2		Z01	12			
	L05C	4		Z02	8			
	L05D	4		Z03	4			
	L15A	2		W05	4			
	L19	4		S03	4			
	L20	2						
	L21	2						

Middle Section Assembly Instruction

PART	NO.	QTY.	PART	NO.	QTY.
	L10A	2		W02	2
	L10B	2		S01	8
	L10C	2		M01	8
	L08B	2		Z01	8
				C	2
				G	2
				H	1
				K	2
				W05	2
				S03	2
				J04	2
				J05	2
				J06	1





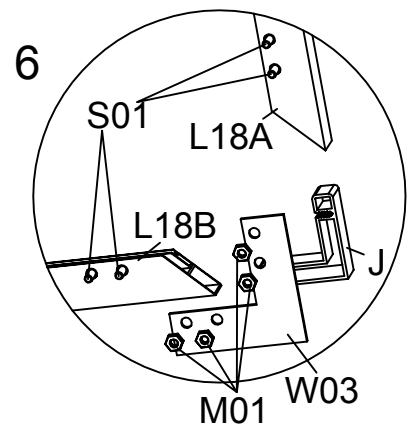
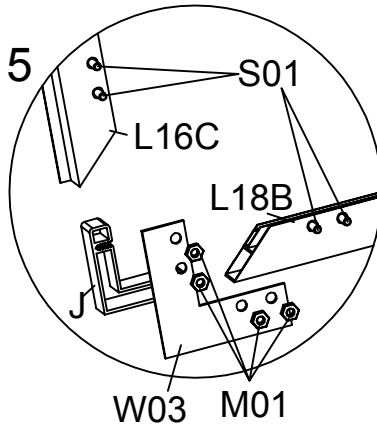
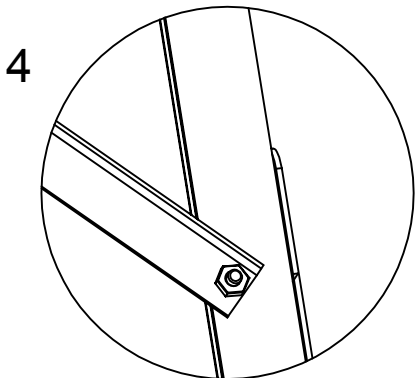
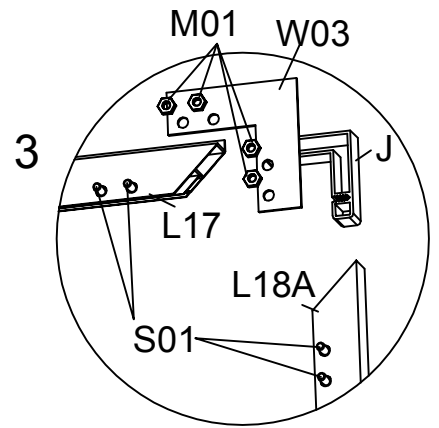
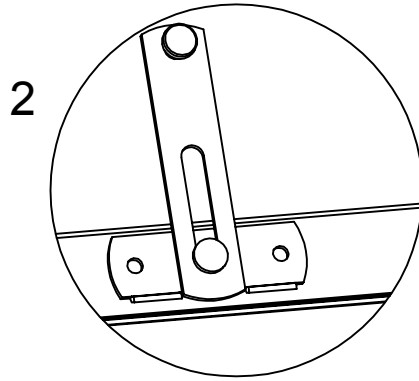
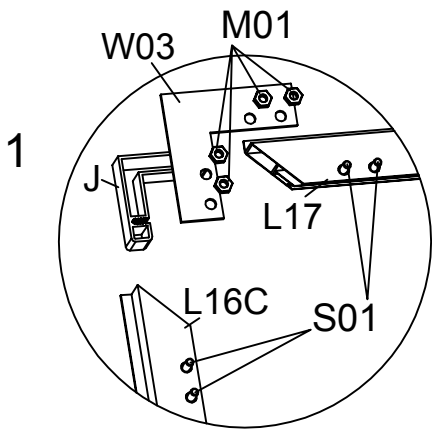
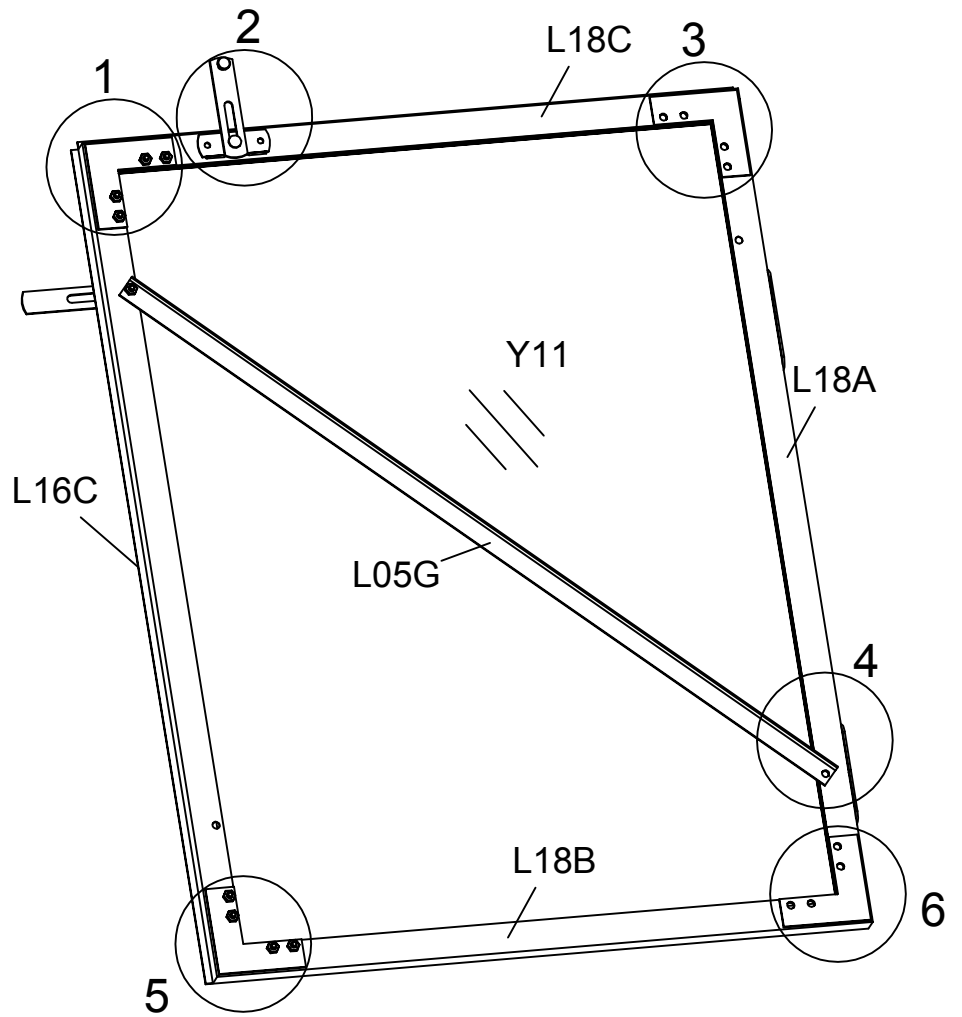



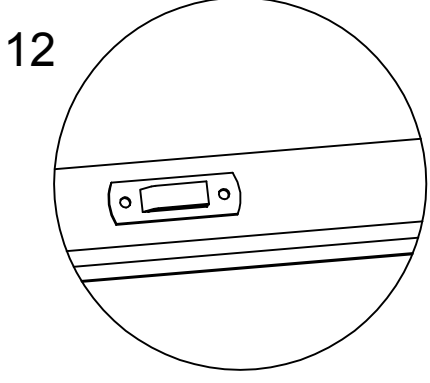
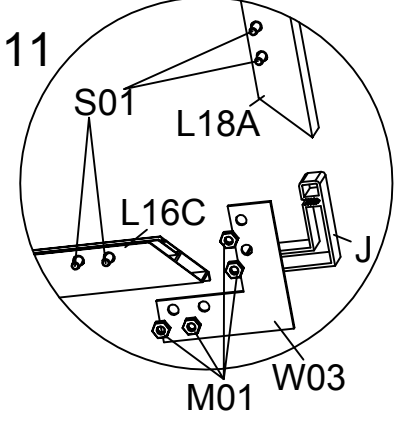
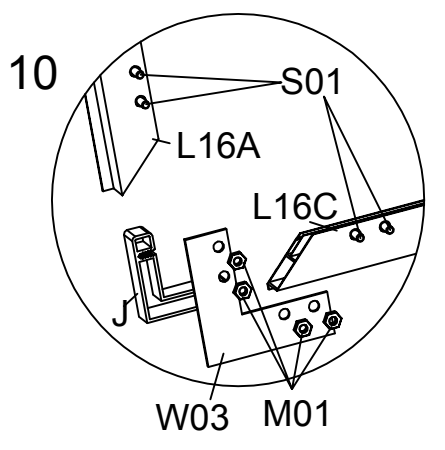
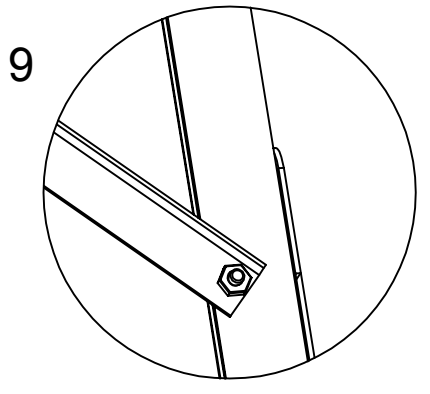
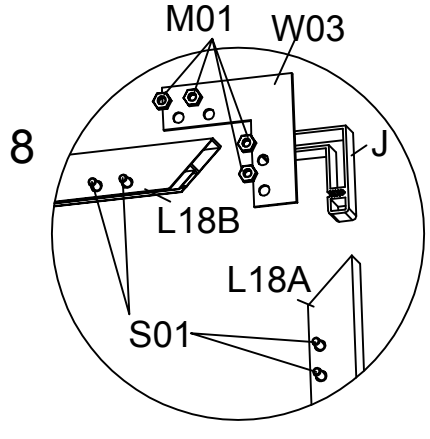
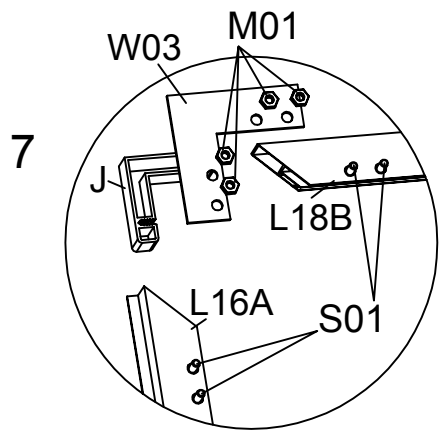
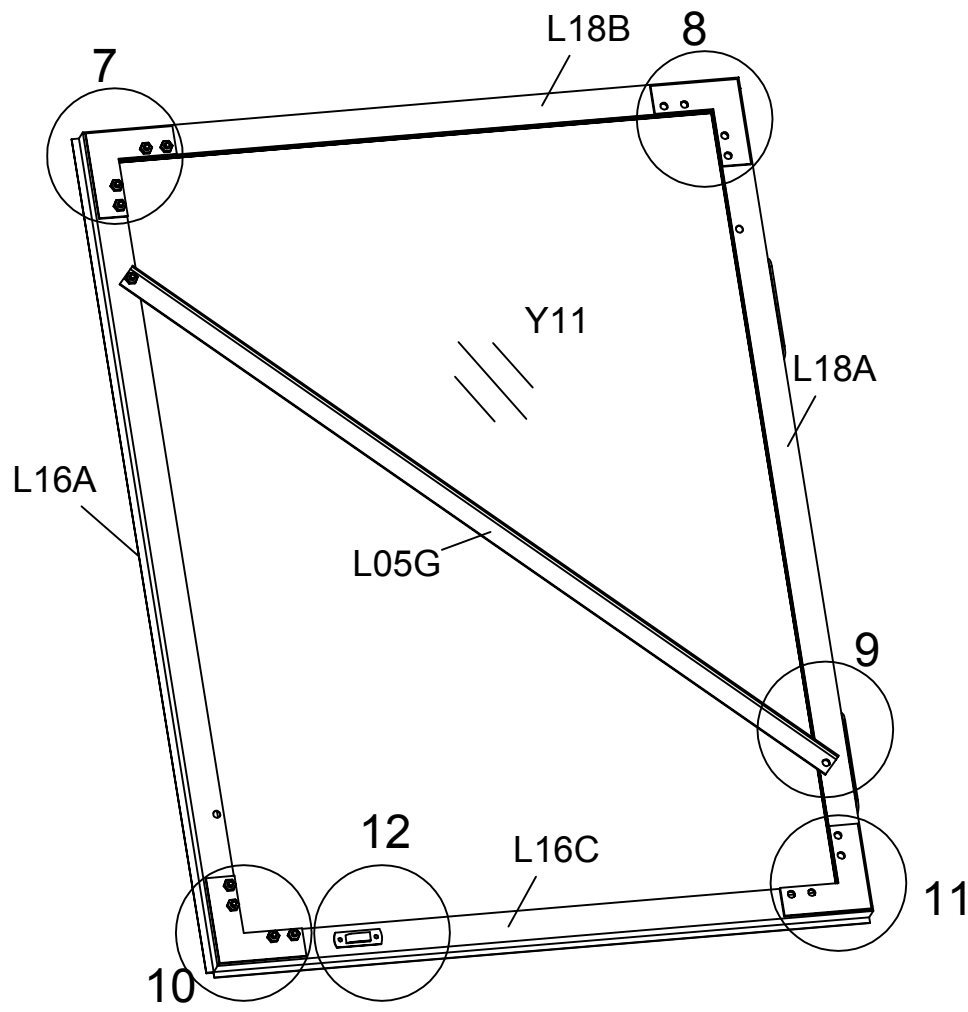

















PART	NO.	QTY.
	L18A	2
	L18B	2
	L17	1
	L16A	1
	L16B	1
	L16C	1
	L05G	2
	J	8
	W03	8
	S01	32
	M01	32
	Y11	2

Door1 Assembly



Door2 Assembly



PART	NO.	QTY.	PART	NO.	QTY.	PART	NO.	QTY.
	L01A	2		A	1		Y1	1
	L01B	1		B	1		Y2	3
	L01C	1		D	1		Y3	1
	L03C	1		E	1		Y4	1
	L03D	1		F	1			
	L04B	3		W01	2			
	L05A	2		S01	18			
	L08A	1		M01	18			
				W05	2			
				S03	2			
				J01	1			
				J02R/L	1/1			
				J03R/L	1/1			
				J07R/L	1/1			
				J08	2			

Back Assembly

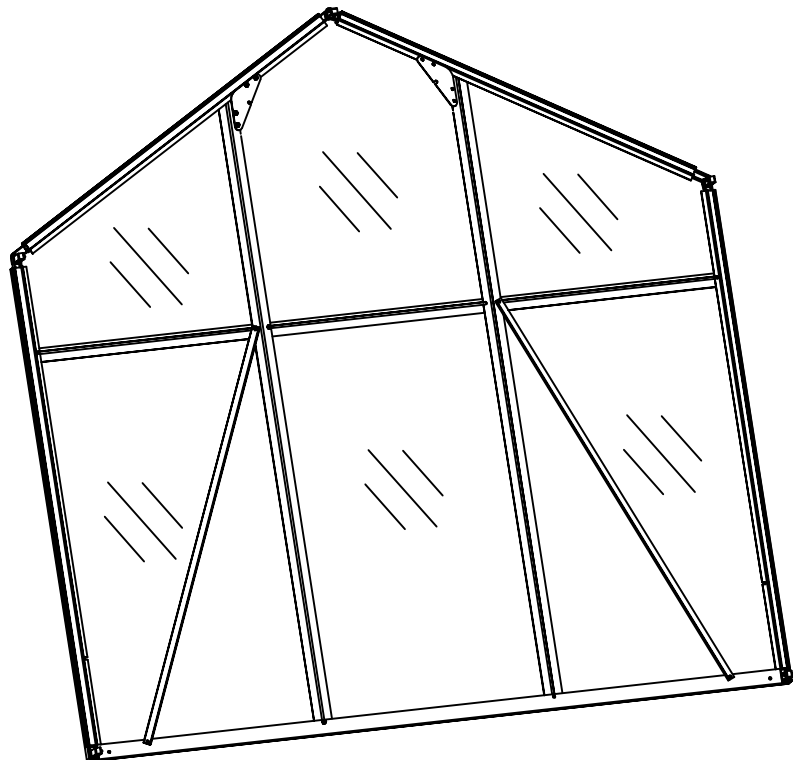

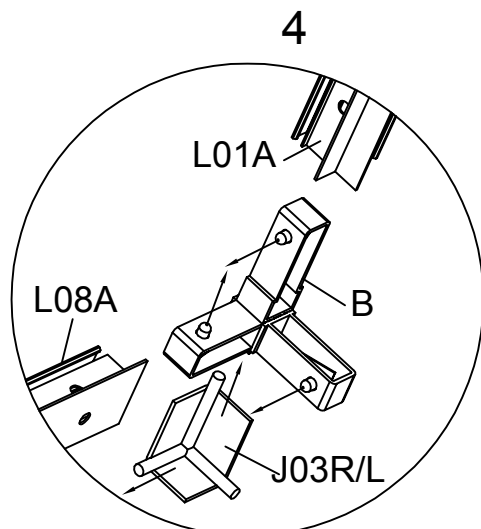
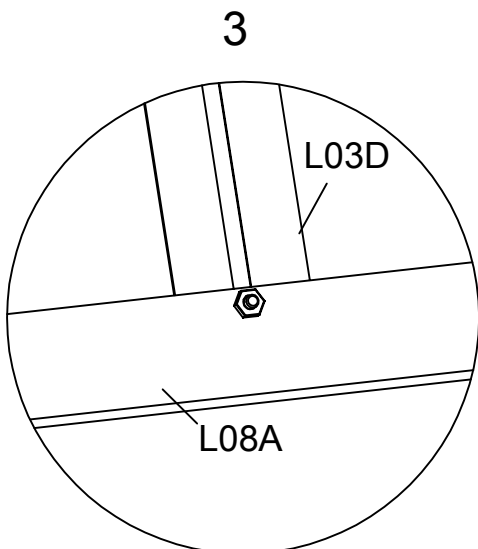
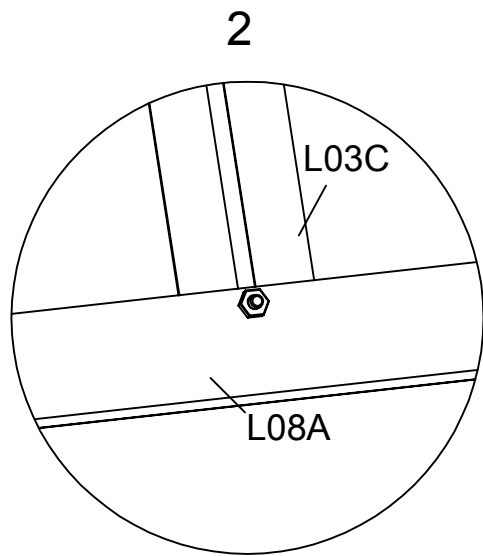
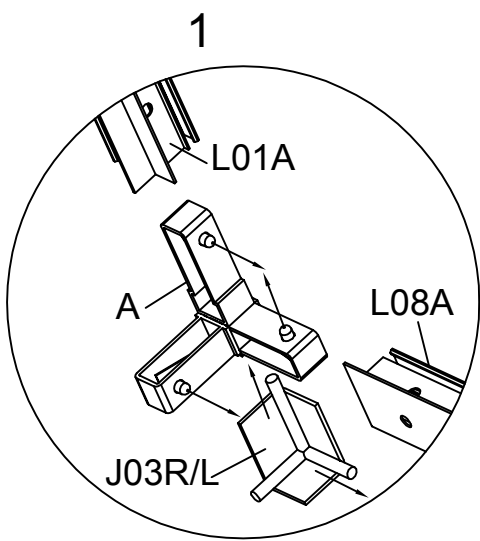
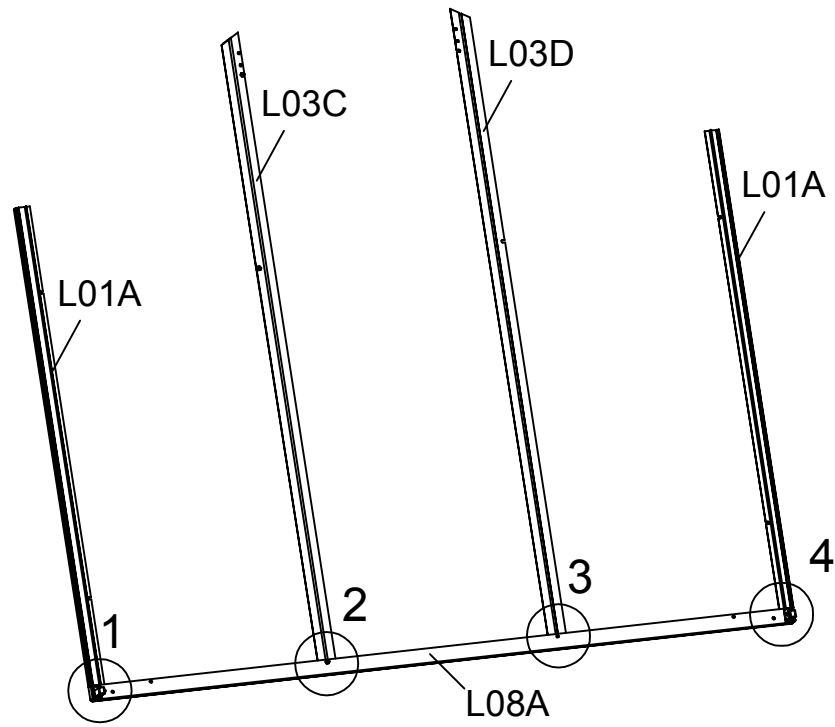

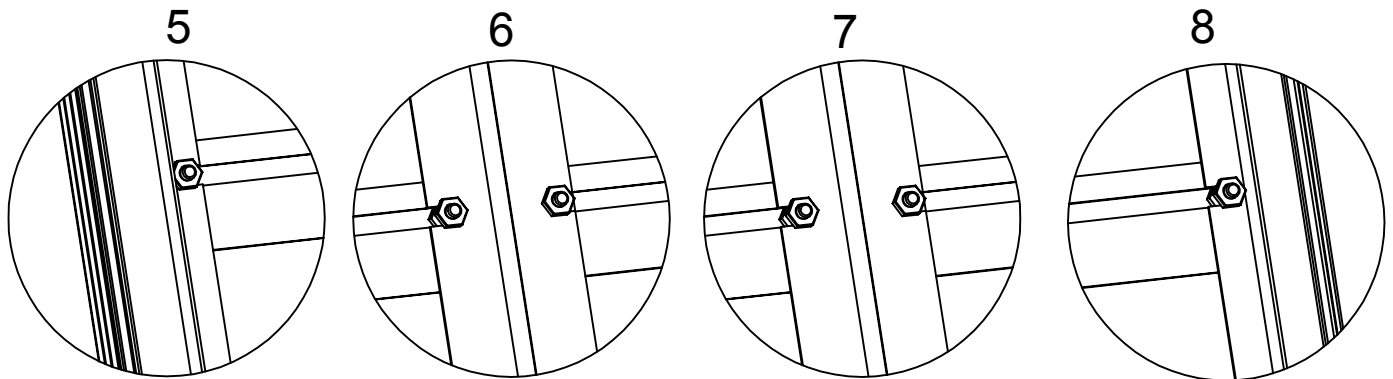
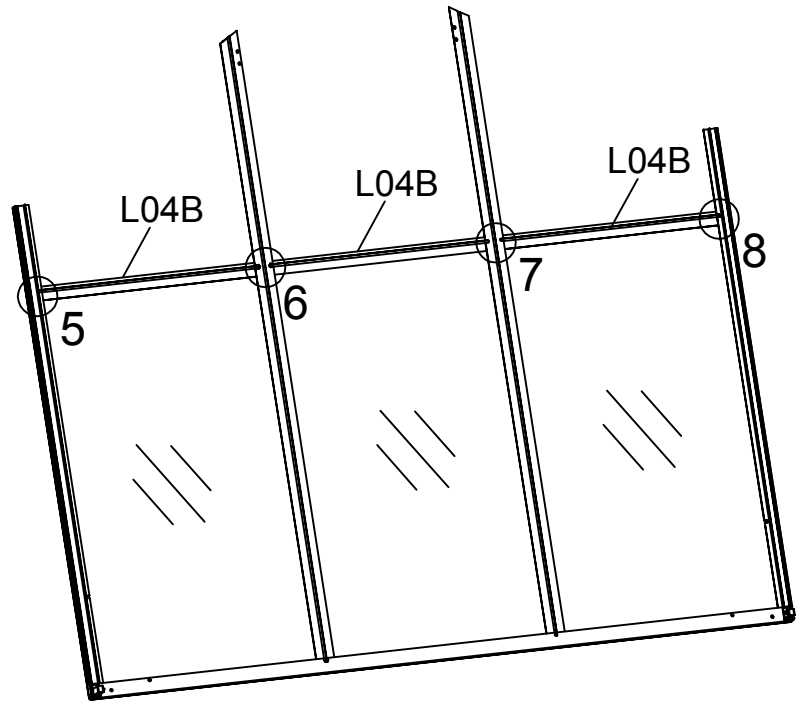
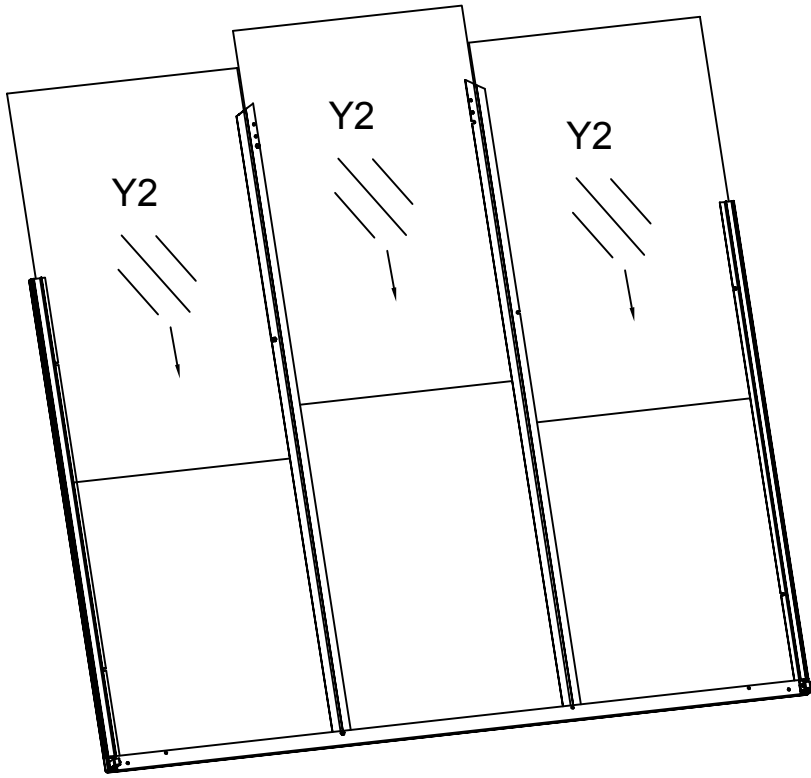

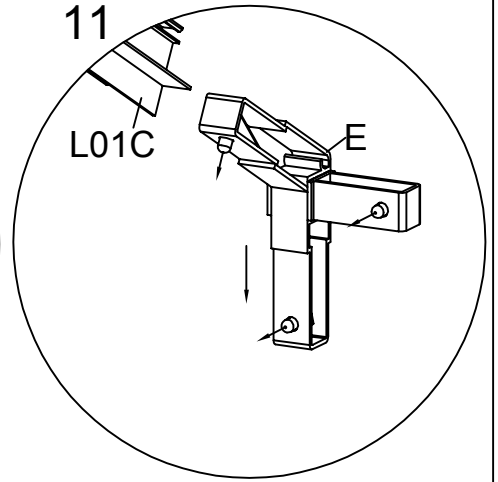
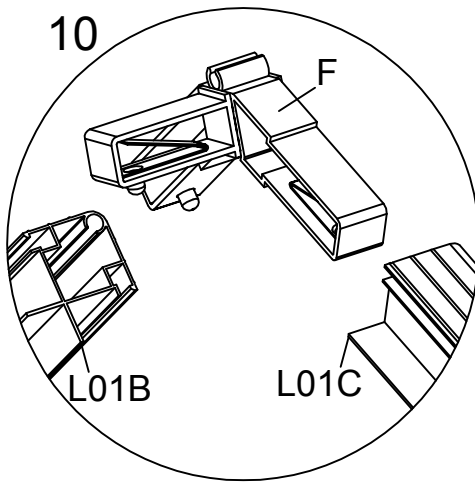
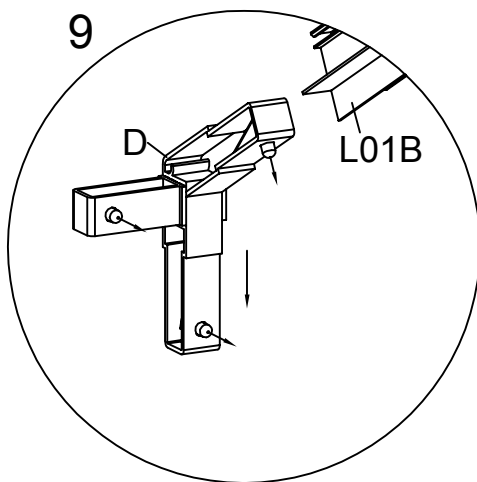
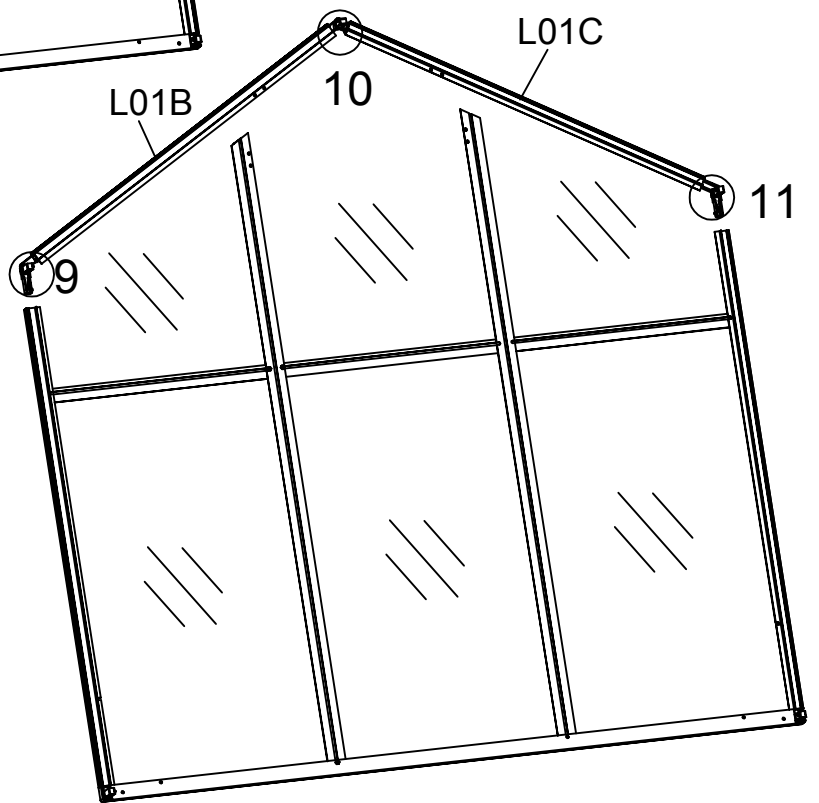
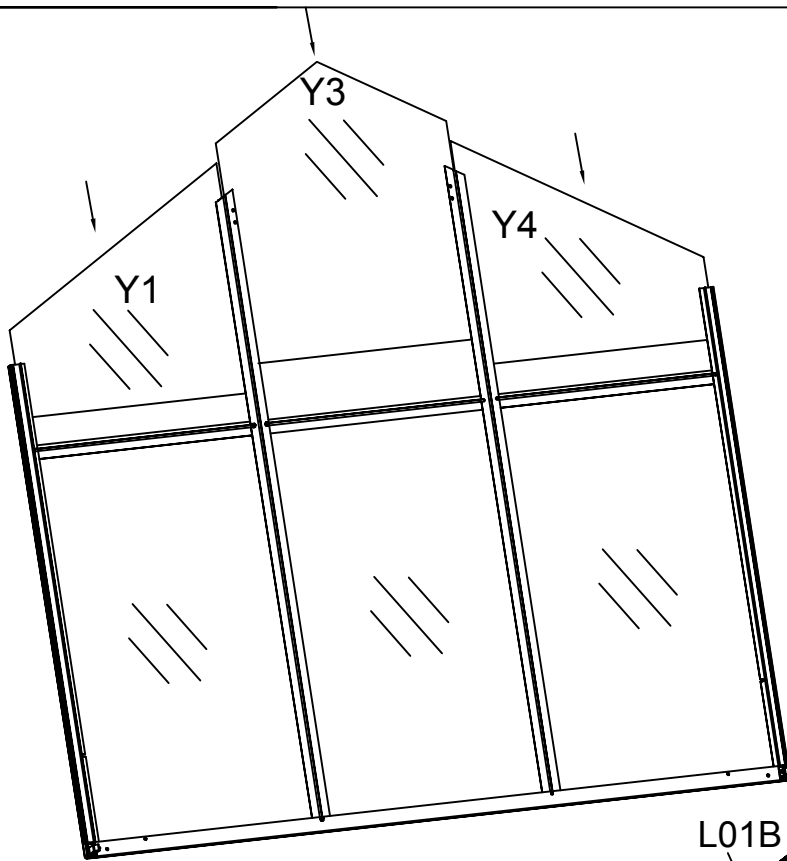

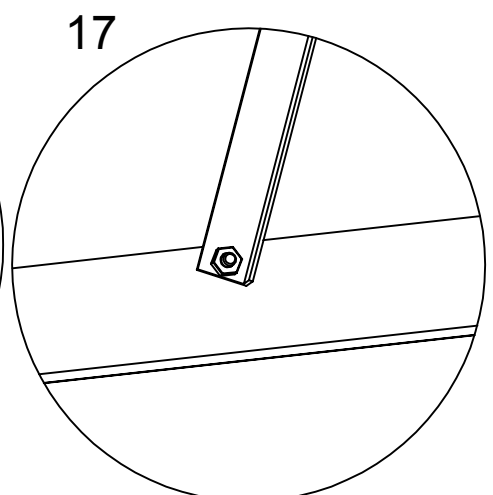
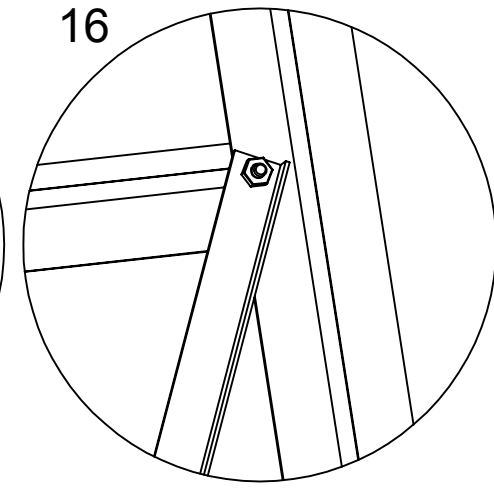
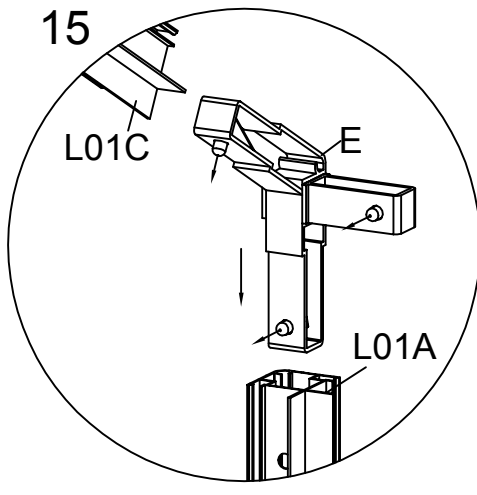
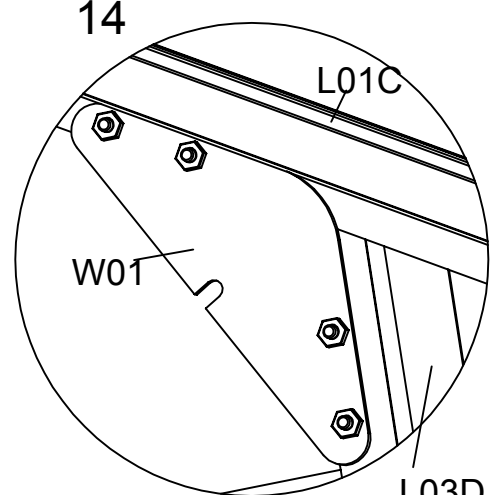
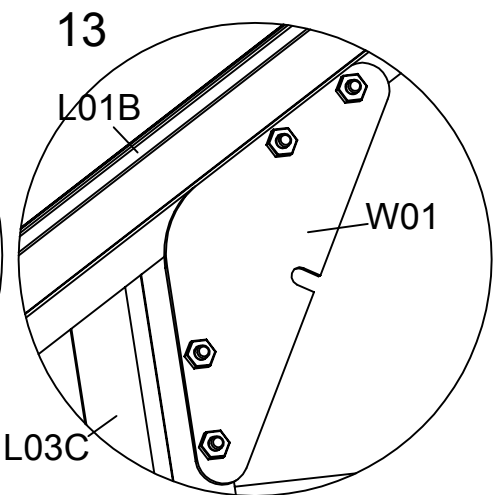
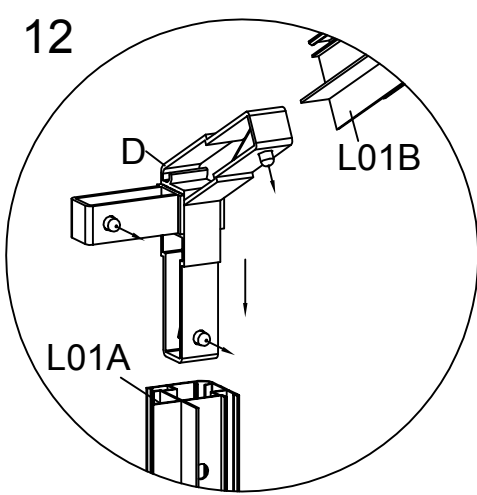
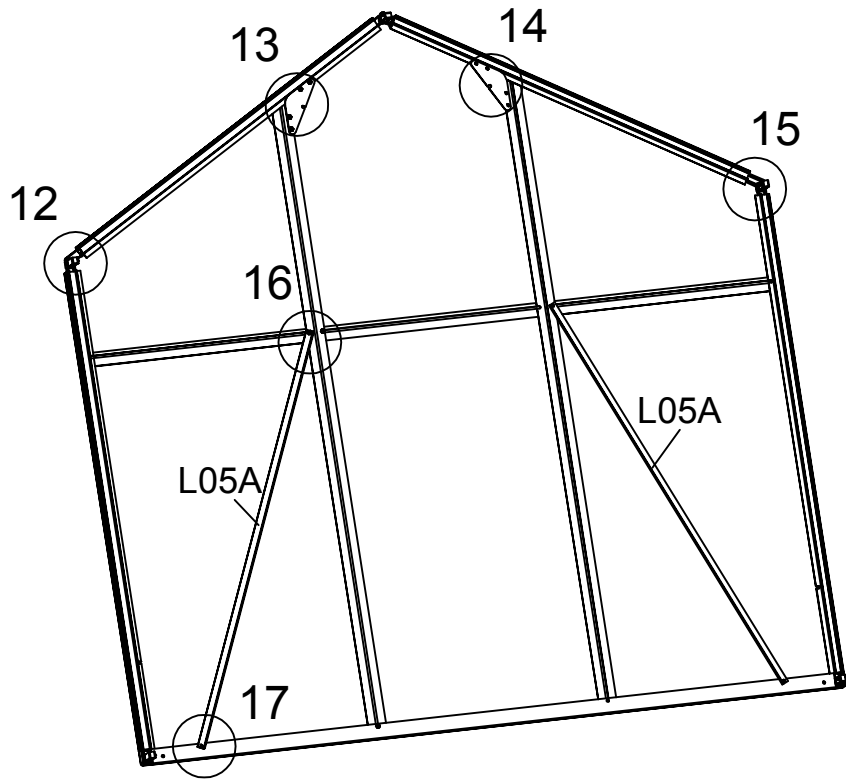



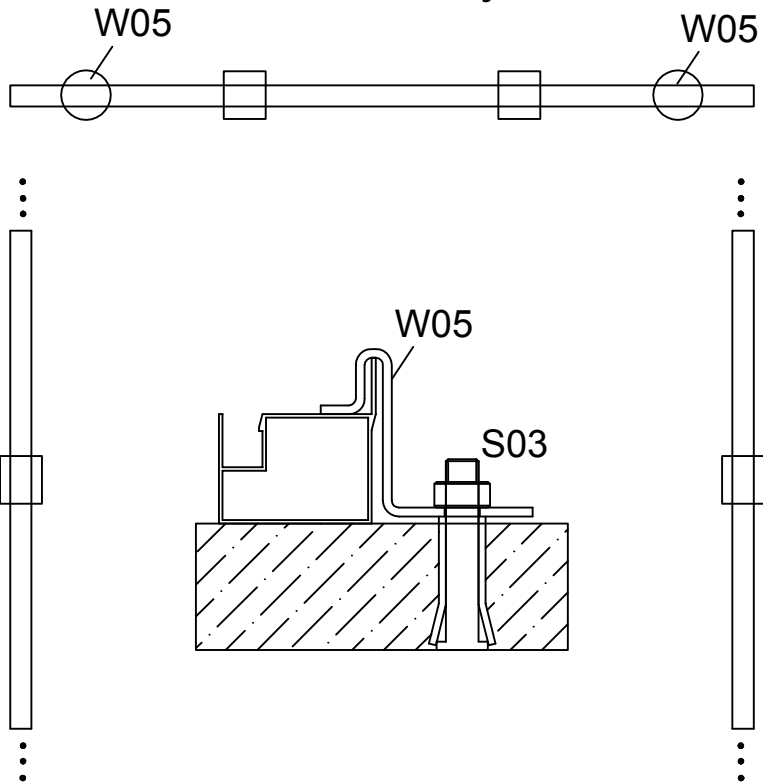

























Back Assembly



PART	NO.	QTY.	PART	NO.	QTY.	PART	NO.	QTY.
	L01A	2		A	1		Y1	1
	L01B	1		B	1		Y2	2
	L01C	1		D	1		Y5	1
	L03E	1		E	1		Y4	1
	L03F	1		F	1			
	L04B	2		W01	2			
	L04A	2		S01	18			
	L05A	2		M01	18			
	L08A	1		W05	2			
				S03	2			
				J01	1			
				J02R/L	1/1			
				J03R/L	1/1			
				J07R/L	1/1			
				J08	2			

Front Assembly

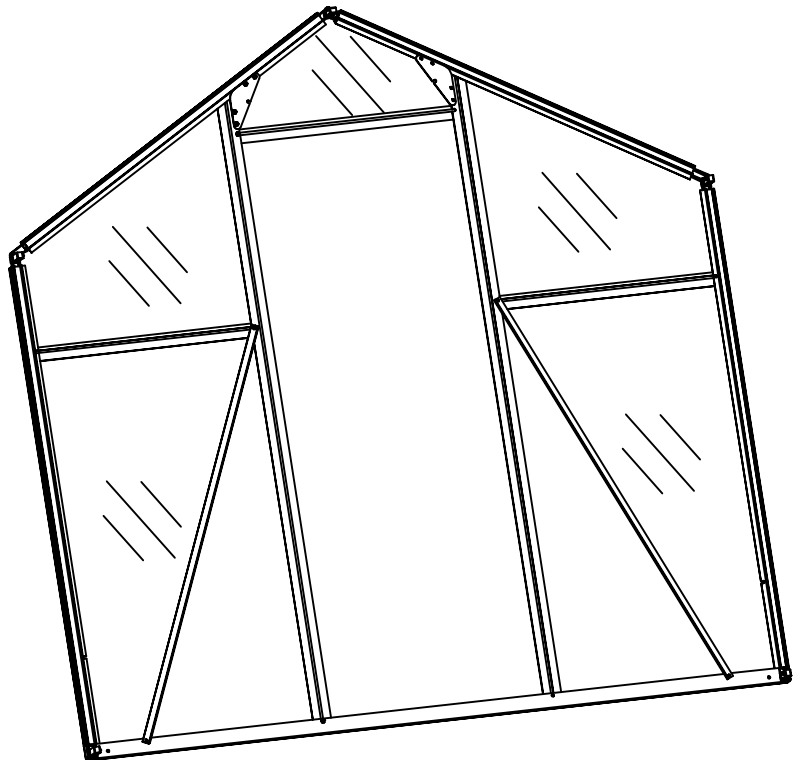

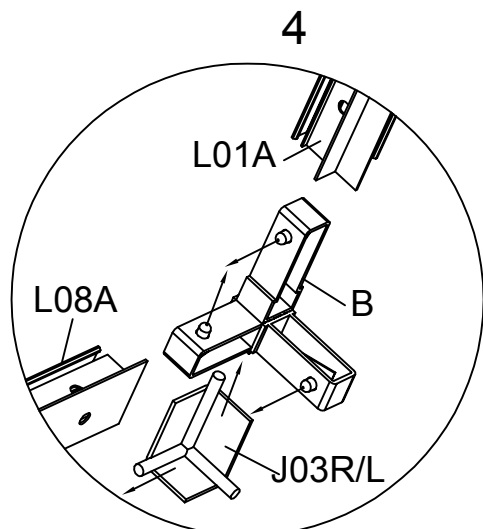
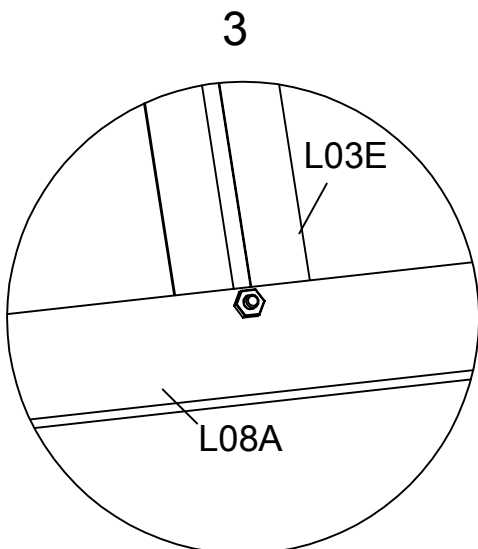
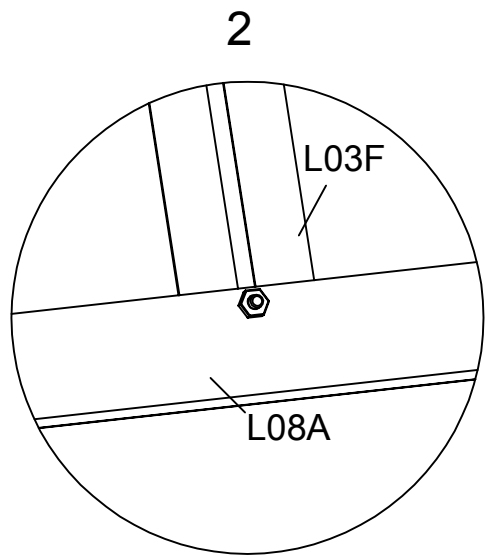
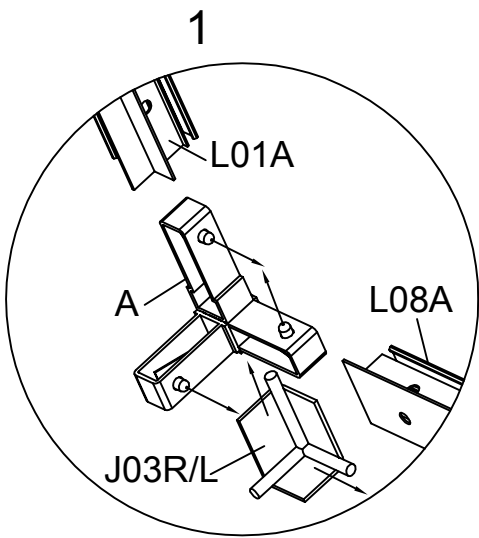
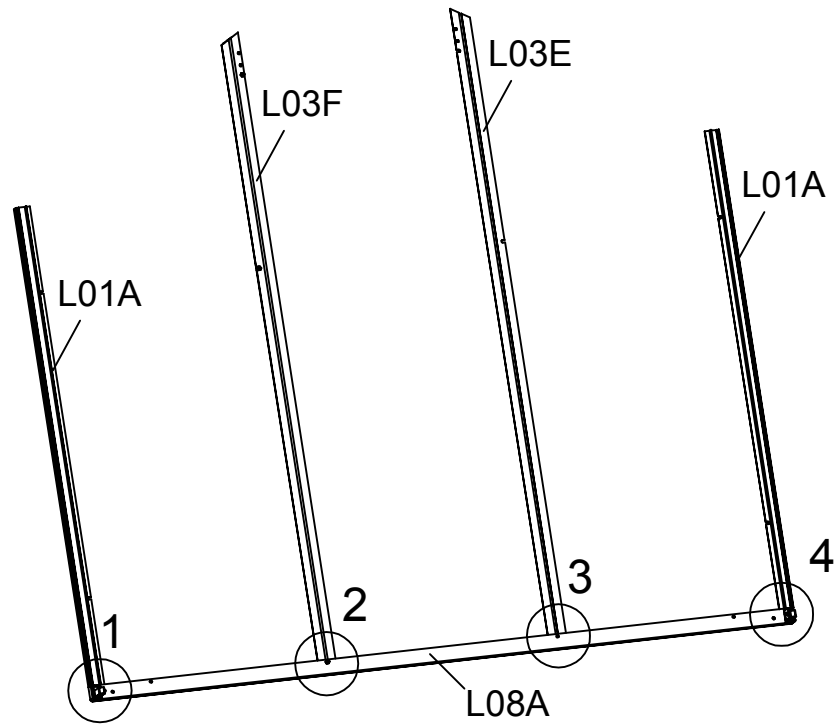

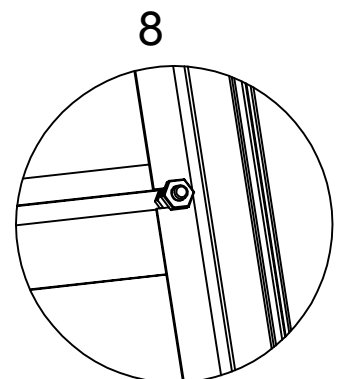
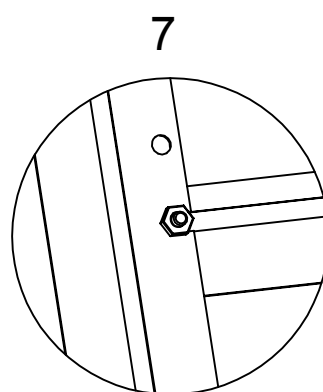
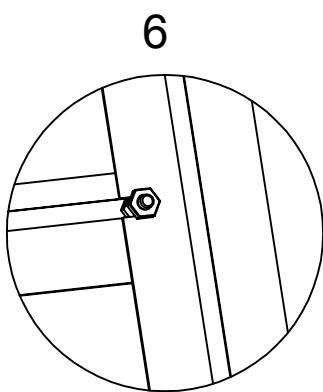
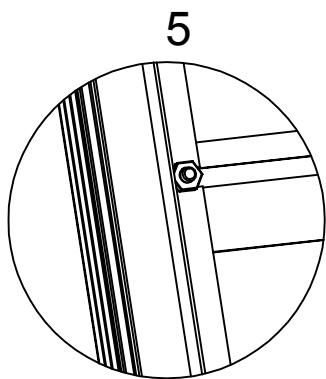
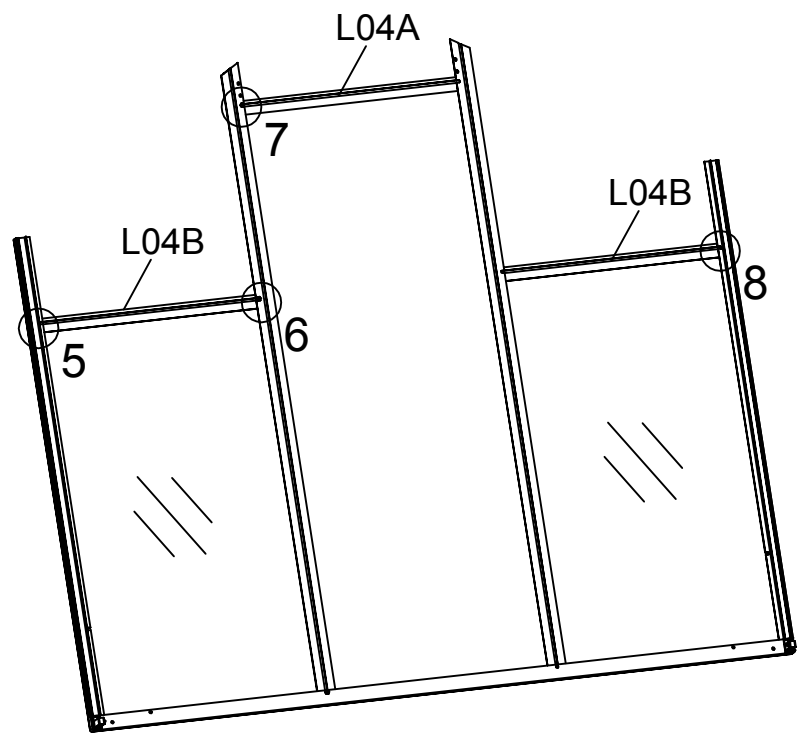
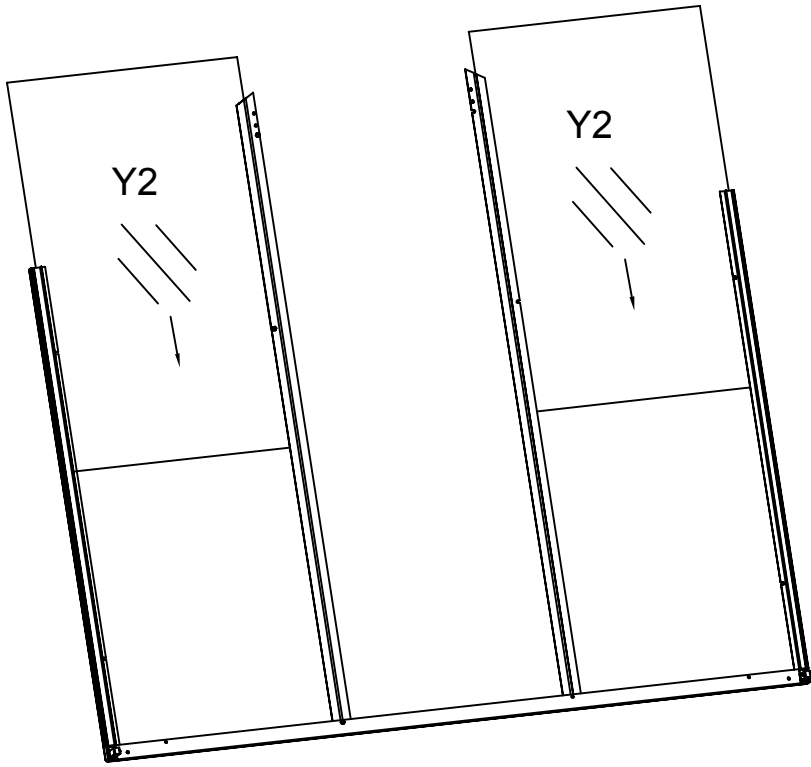

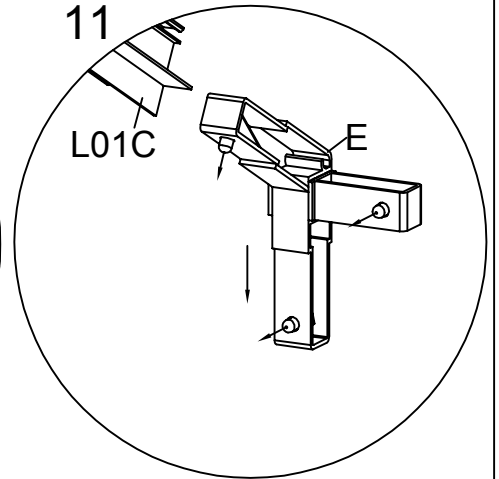
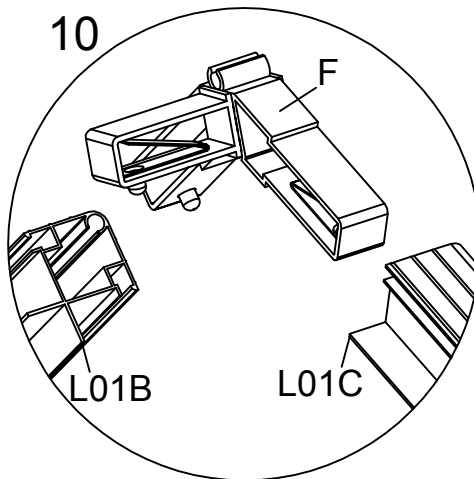
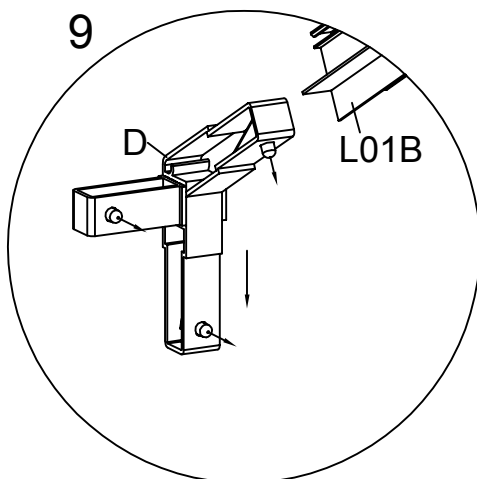
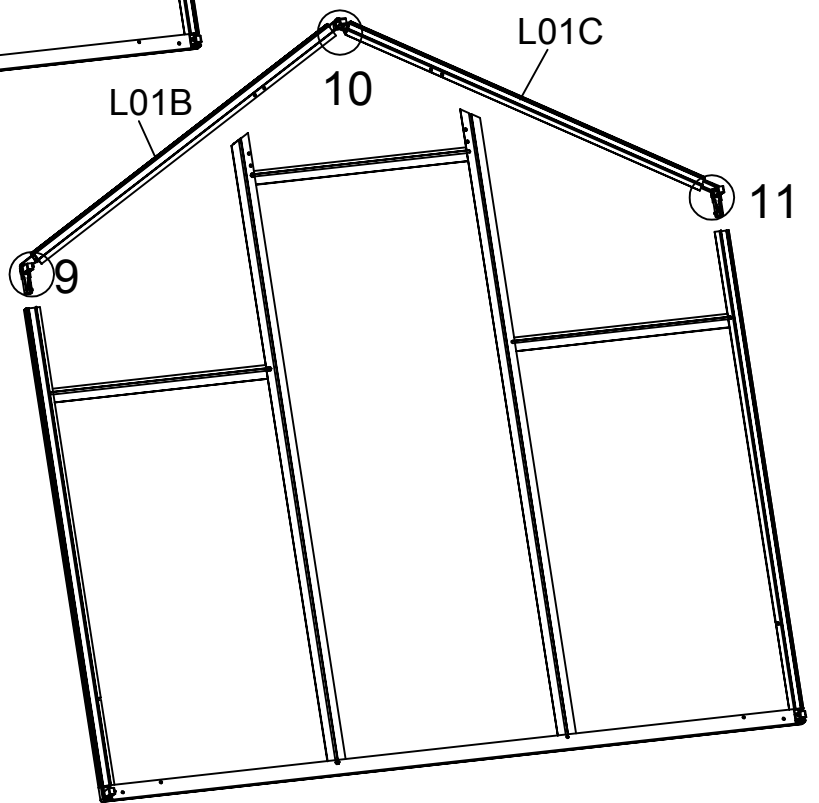
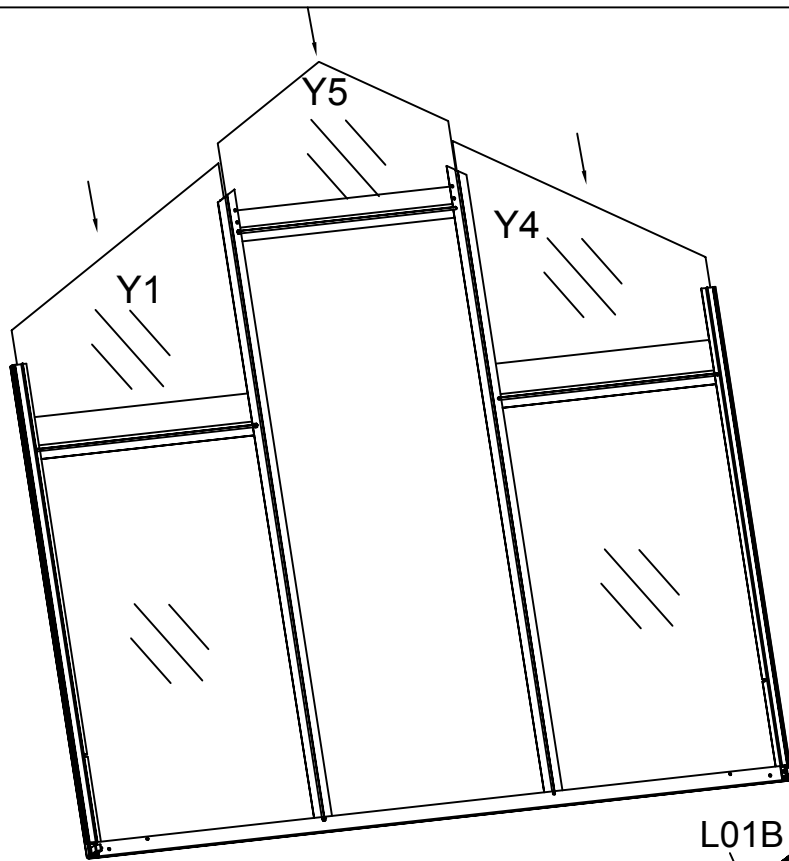

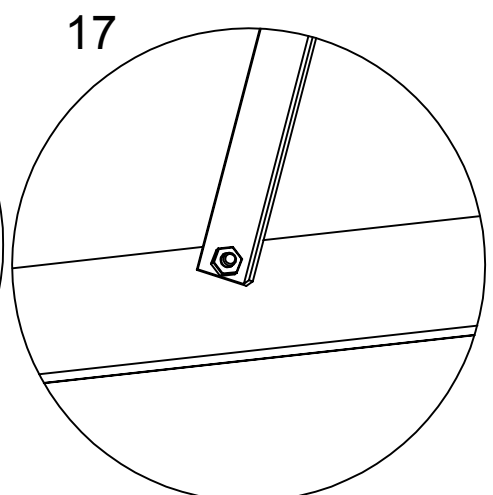
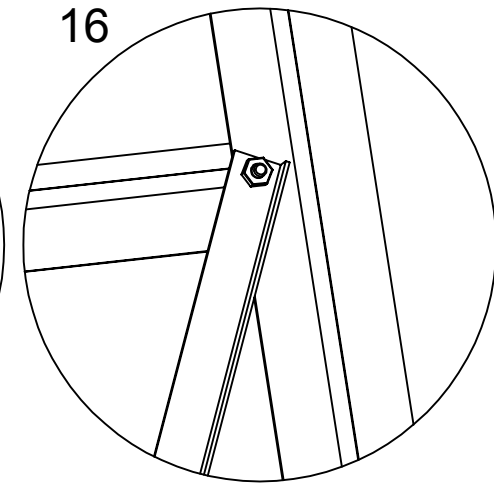
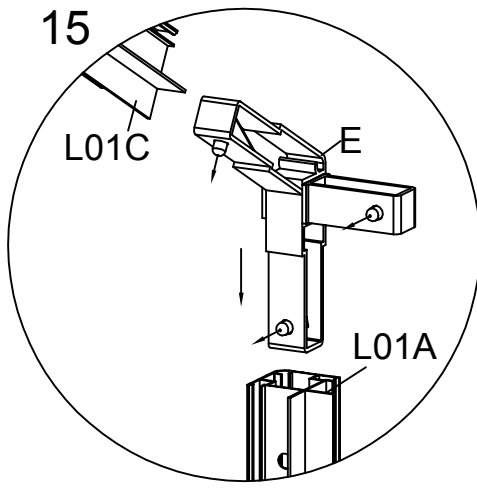
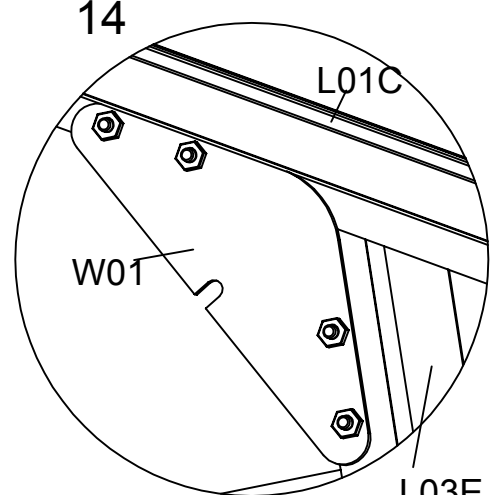
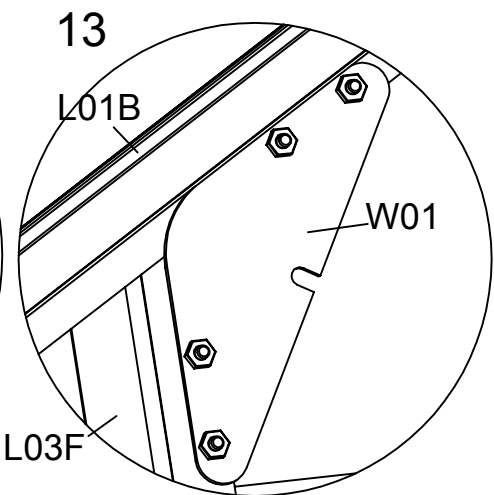
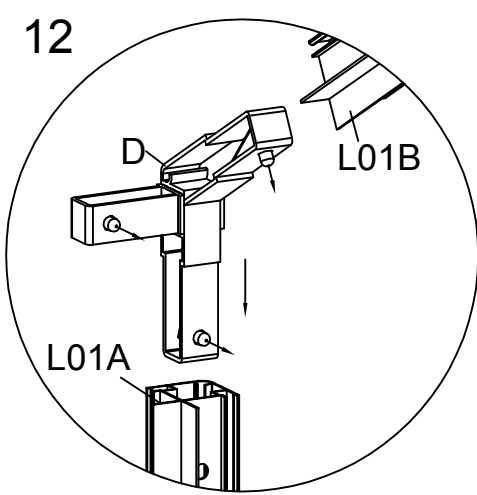
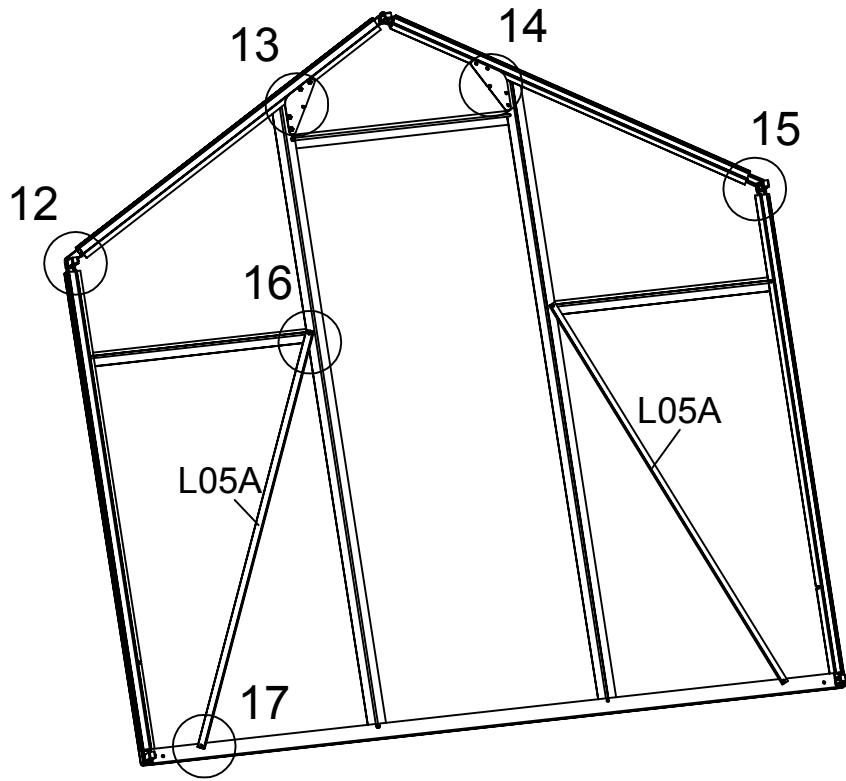

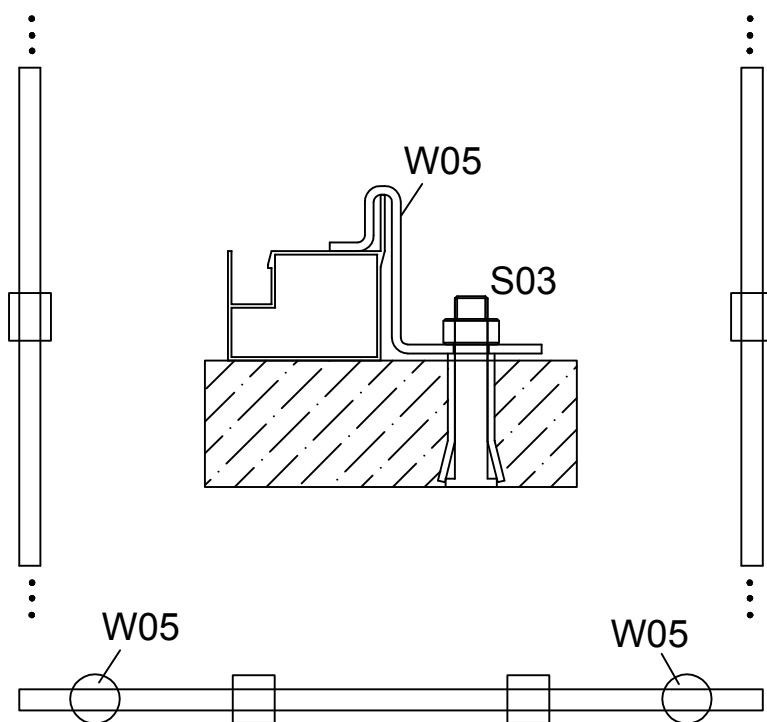



























Front Assembly

PART	NO.	QTY.	PART	NO.	QTY.	PART	NO.	QTY.
	L02A	2		W06	2		Y6	4
	L02B	2		W08	2		Y7	2
	L06	1		W04	2		Y9	2
	L07	2		S01	22		Y10	2
	L08C	2		M01	22			
	L09	2		Z01	12			
	L05C	2		Z02	6			
	L05D	2		Z03	4			
	L15A	2		W05	4			
	L19	4		S03	4			
	L20	2						
	L21	2						

2 Sections Assembly Instruction

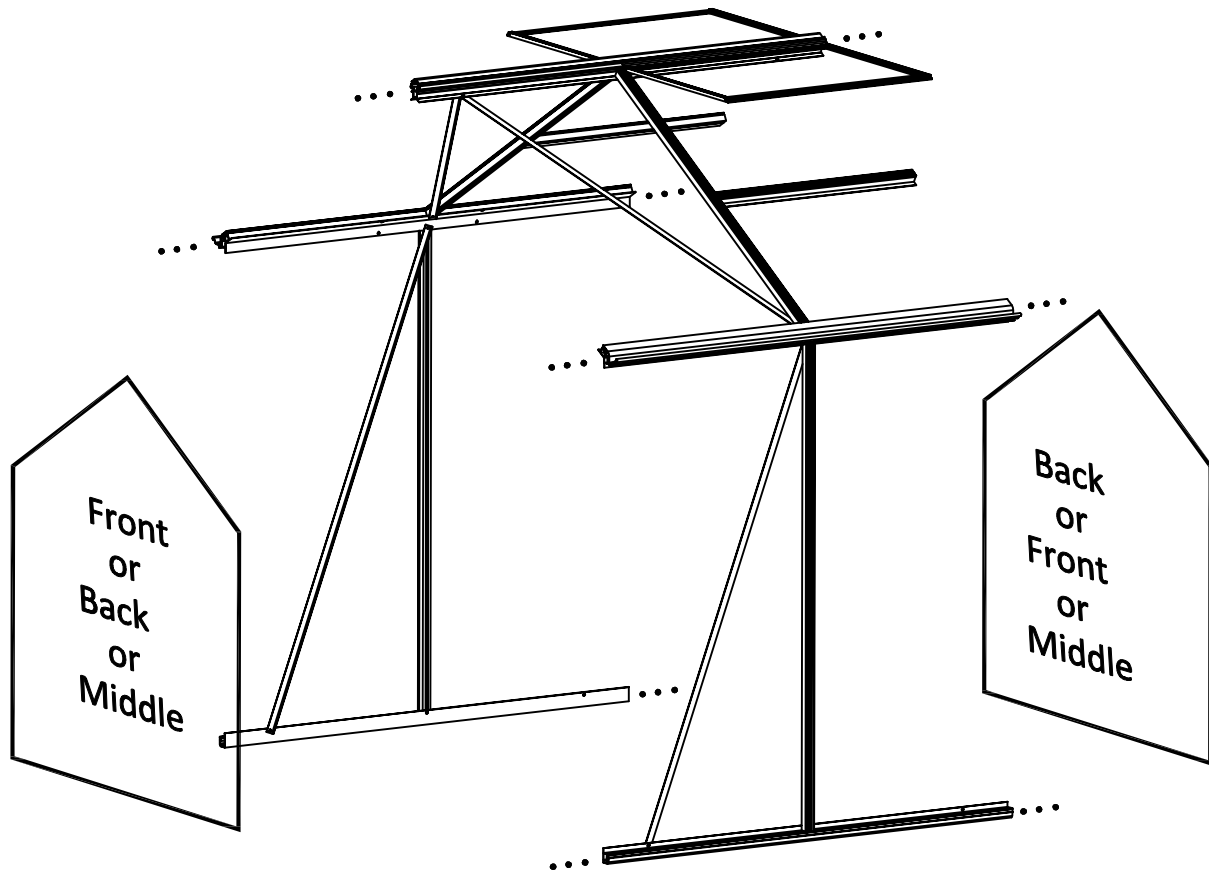

Roof Vent Assembly

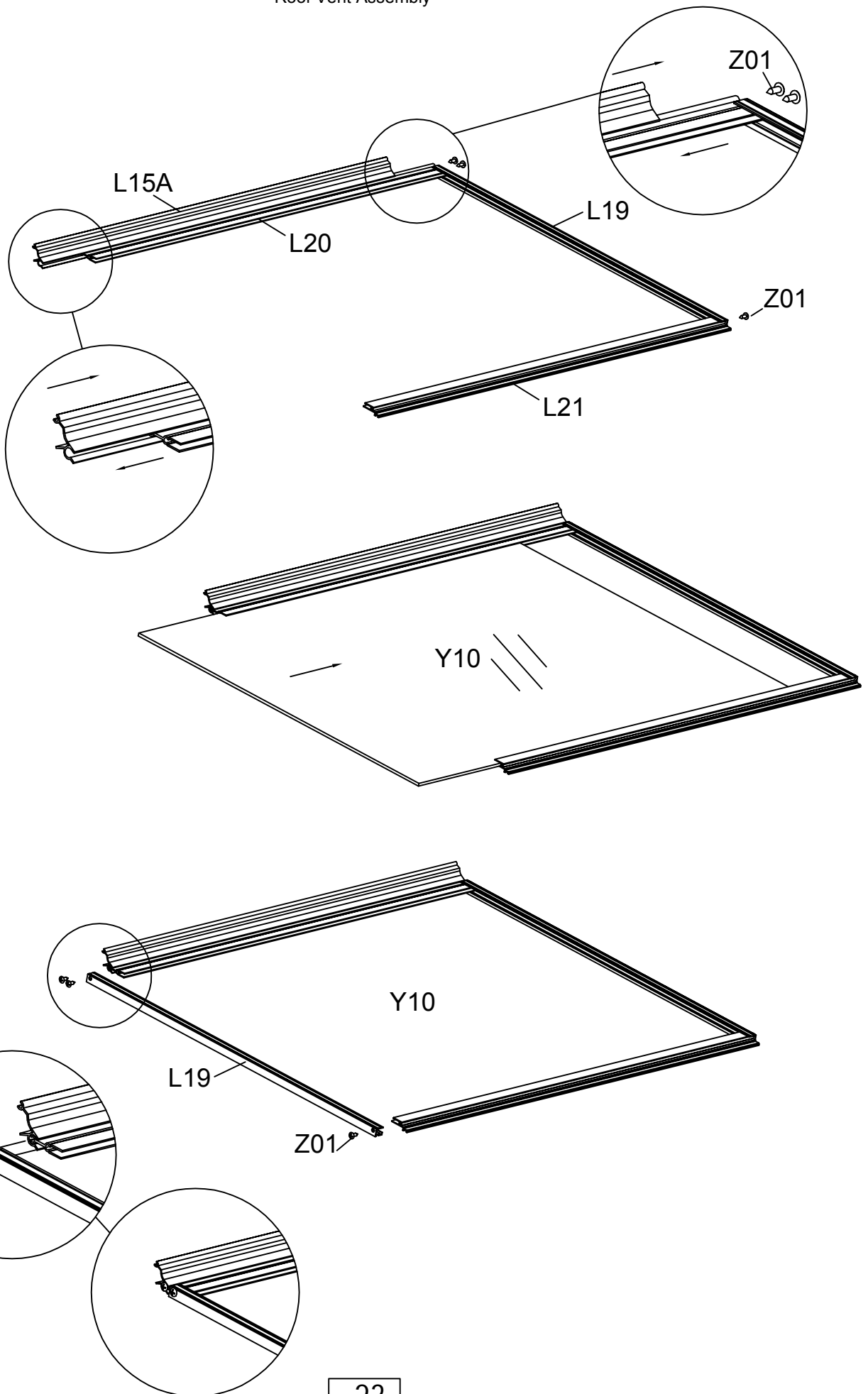

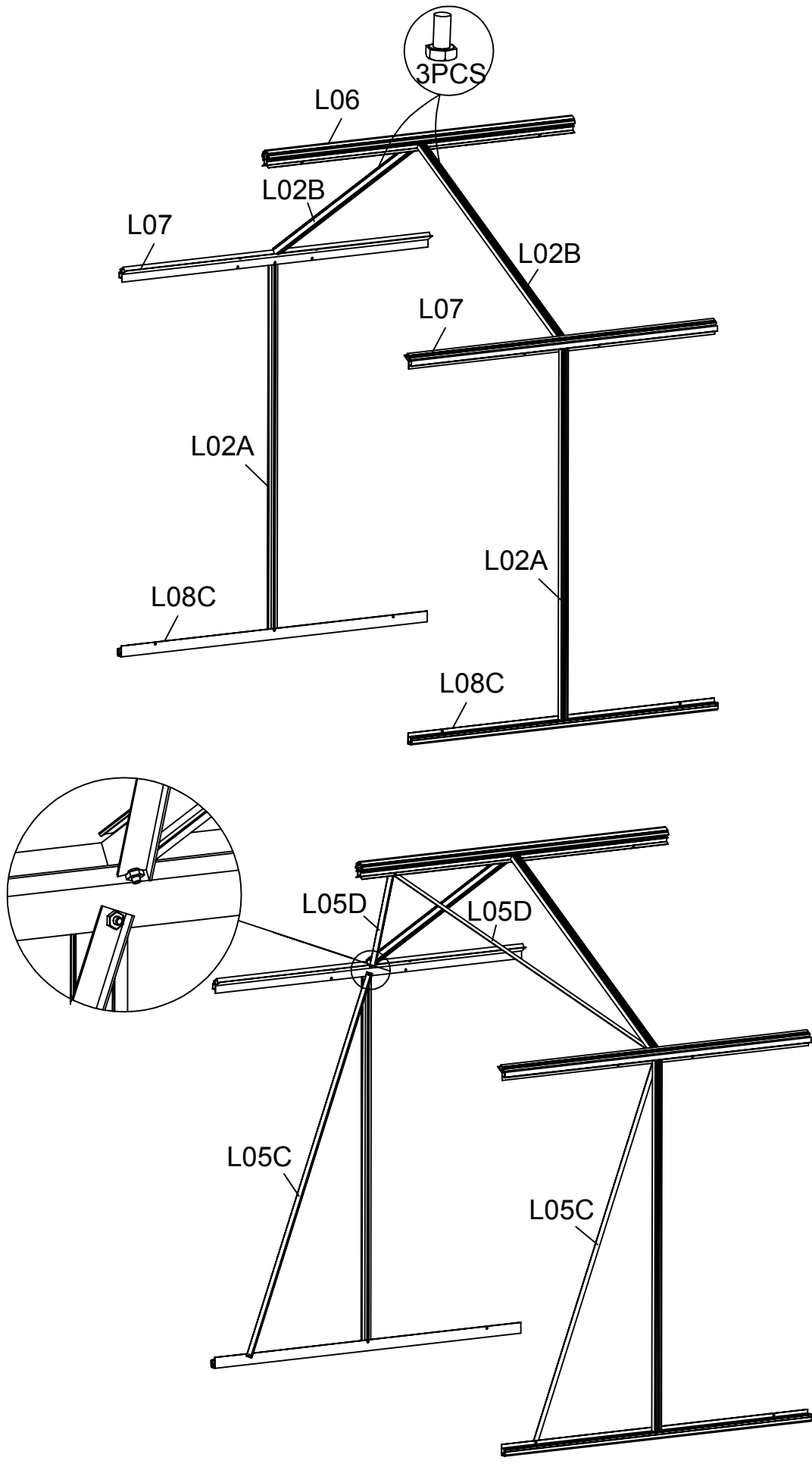

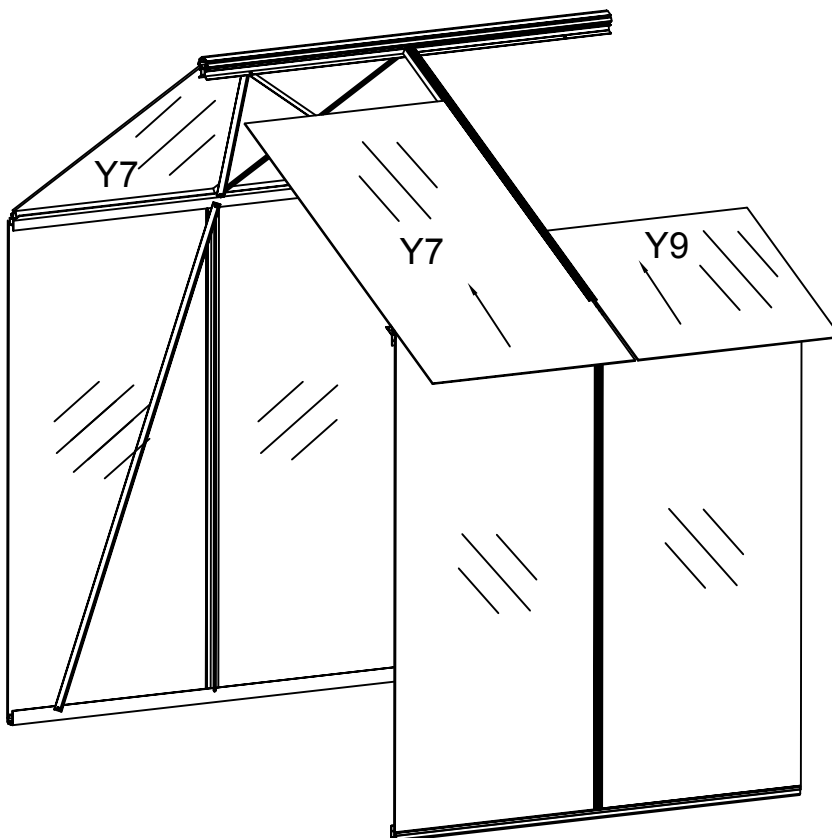
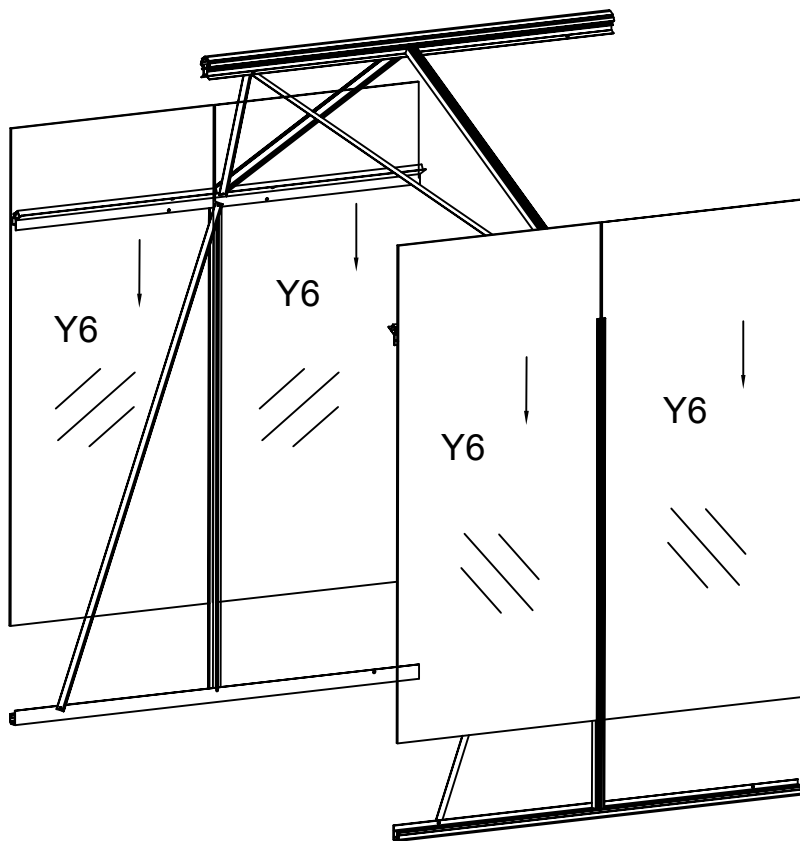

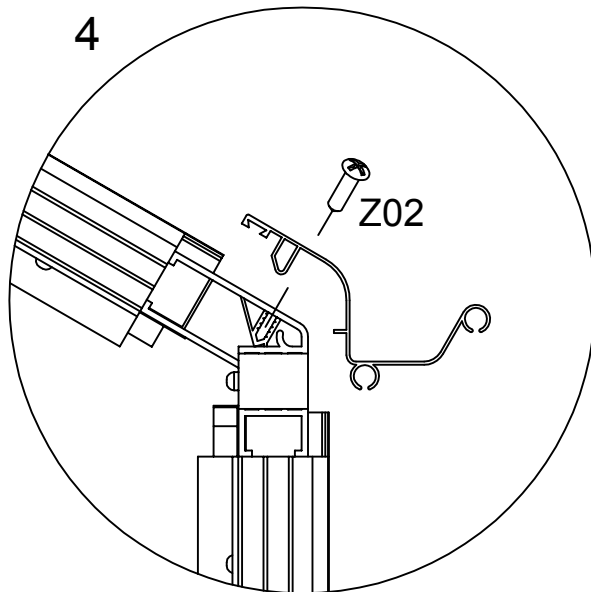
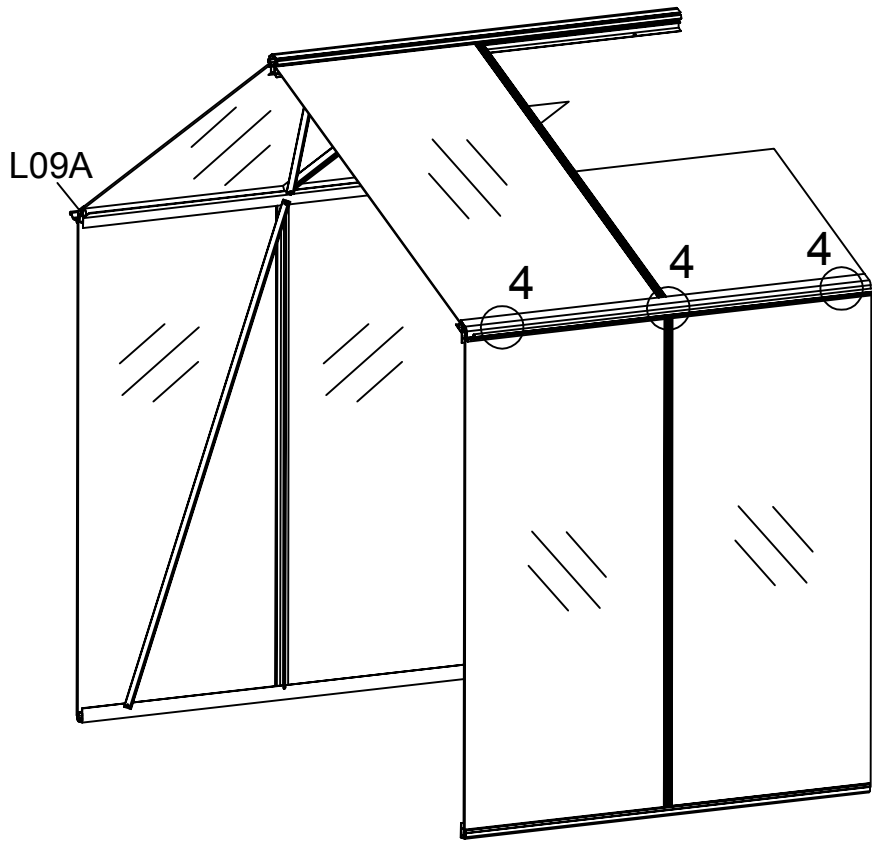

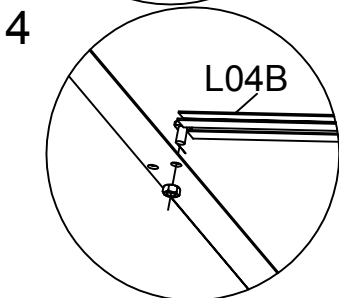
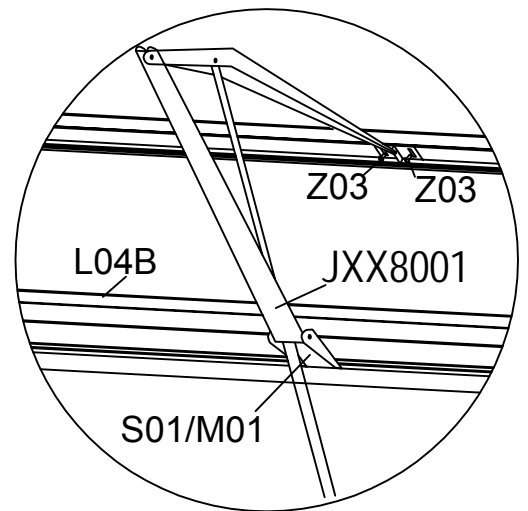
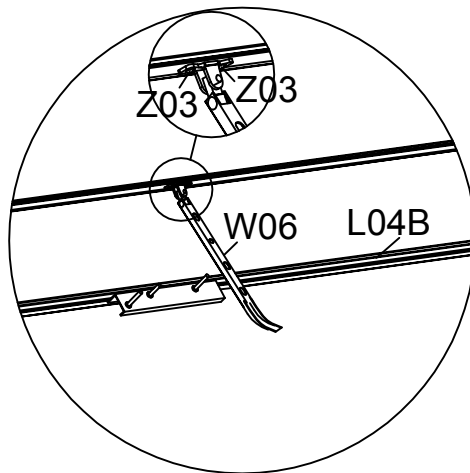
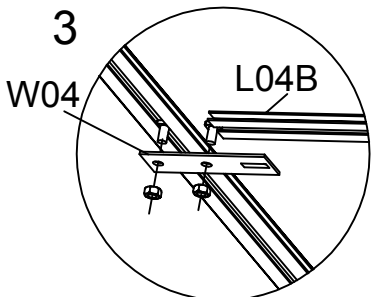
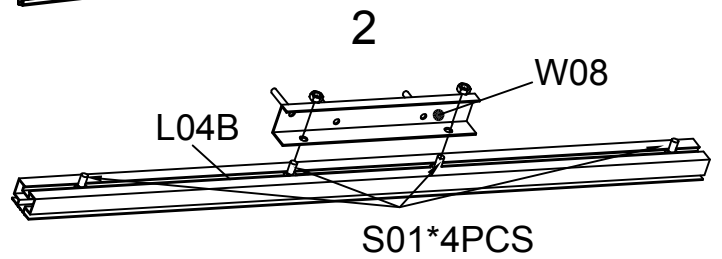
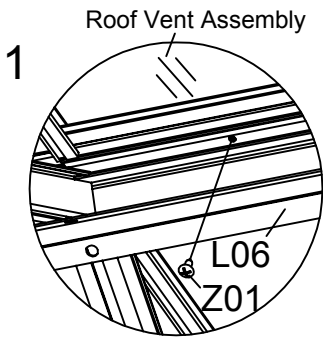
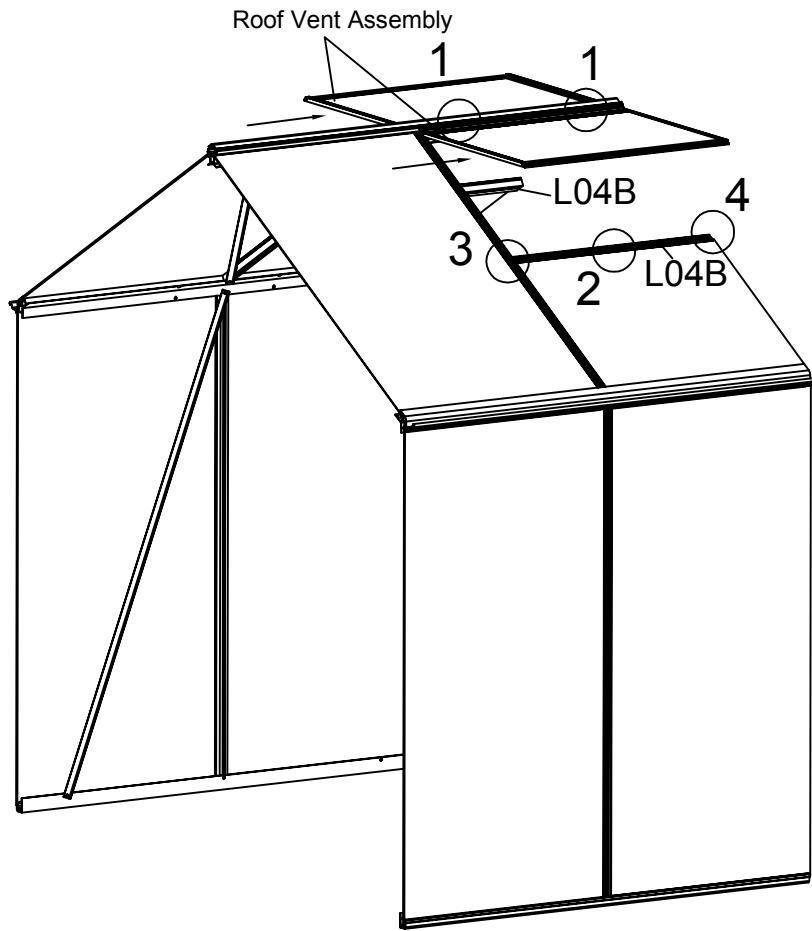

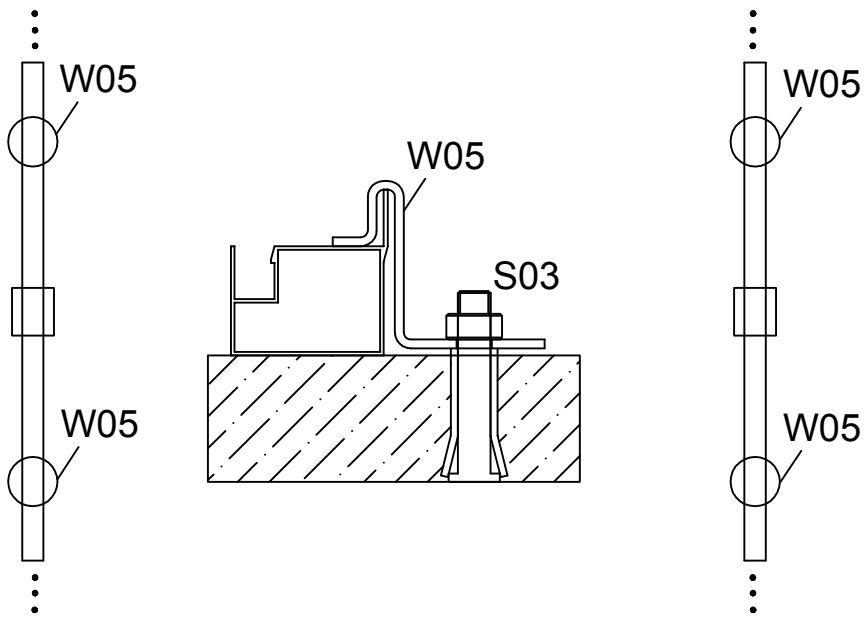



























PART	NO.	QTY.	PART	NO.	QTY.	PART	NO.	QTY.
	L02A	4		W06	2		Y6	6
	L02B	4		W08	2		Y7	4
	L06A	1		W04	4		Y9	2
	L07A	2		S01	36		Y10	2
	L08D	2		M01	36			
	L09A	2		Z01	12			
	L05C	4		Z02	8			
	L05D	4		Z03	4			
	L15A	2		W05	4			
	L19	4		S03	4			
	L20	2						
	L21	2						

3 Sections Assembly Instruction

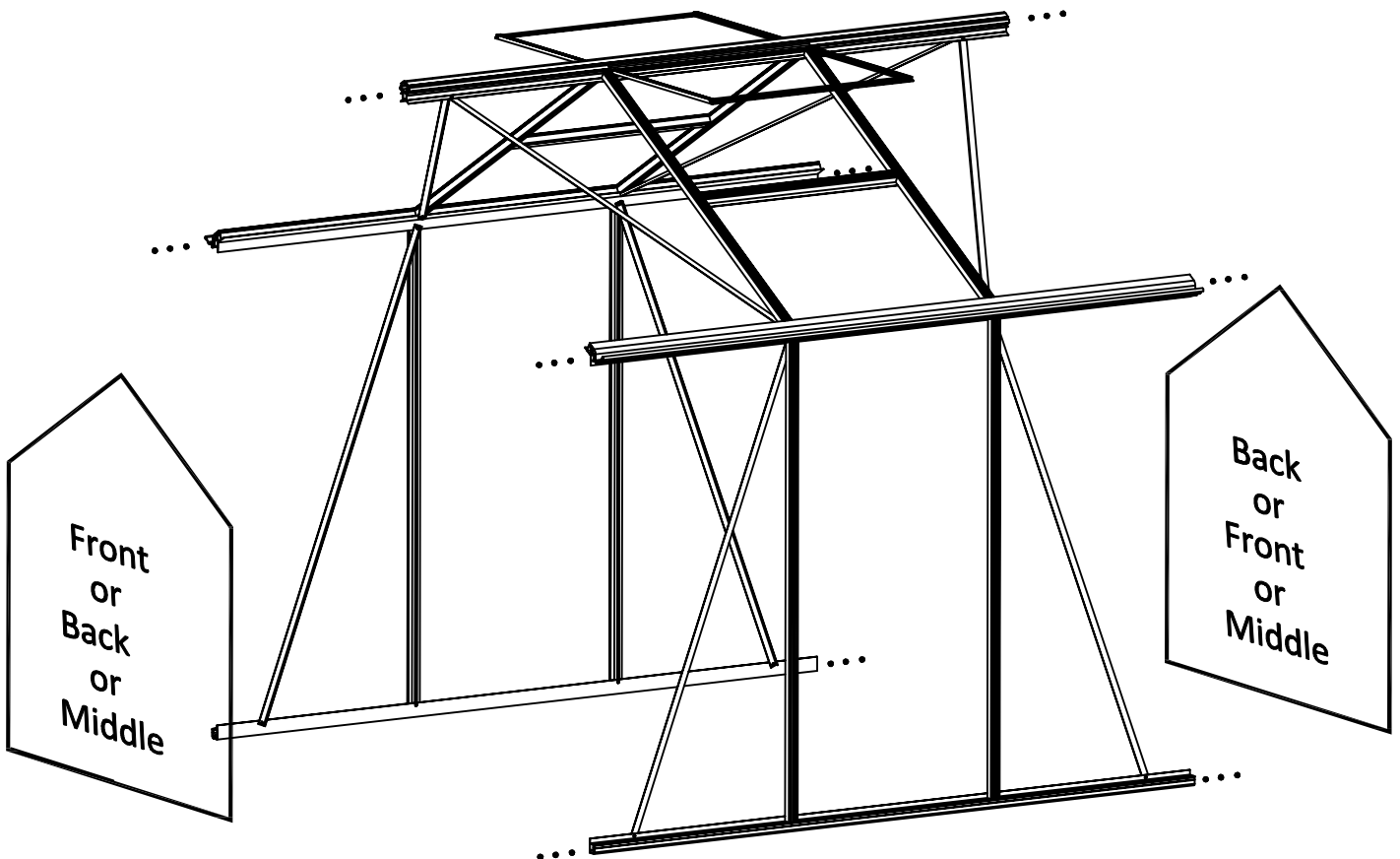

Roof Vent Assembly

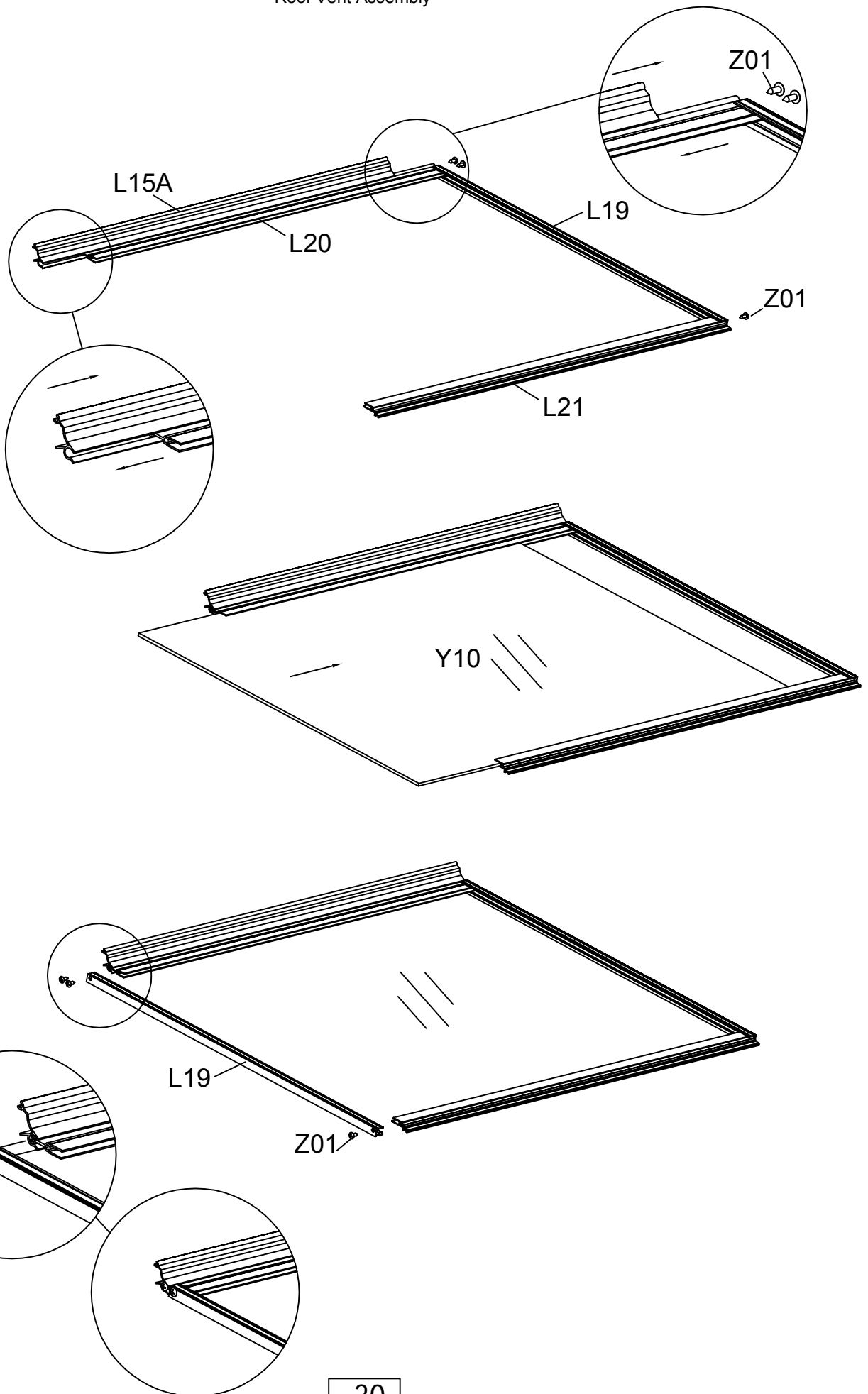

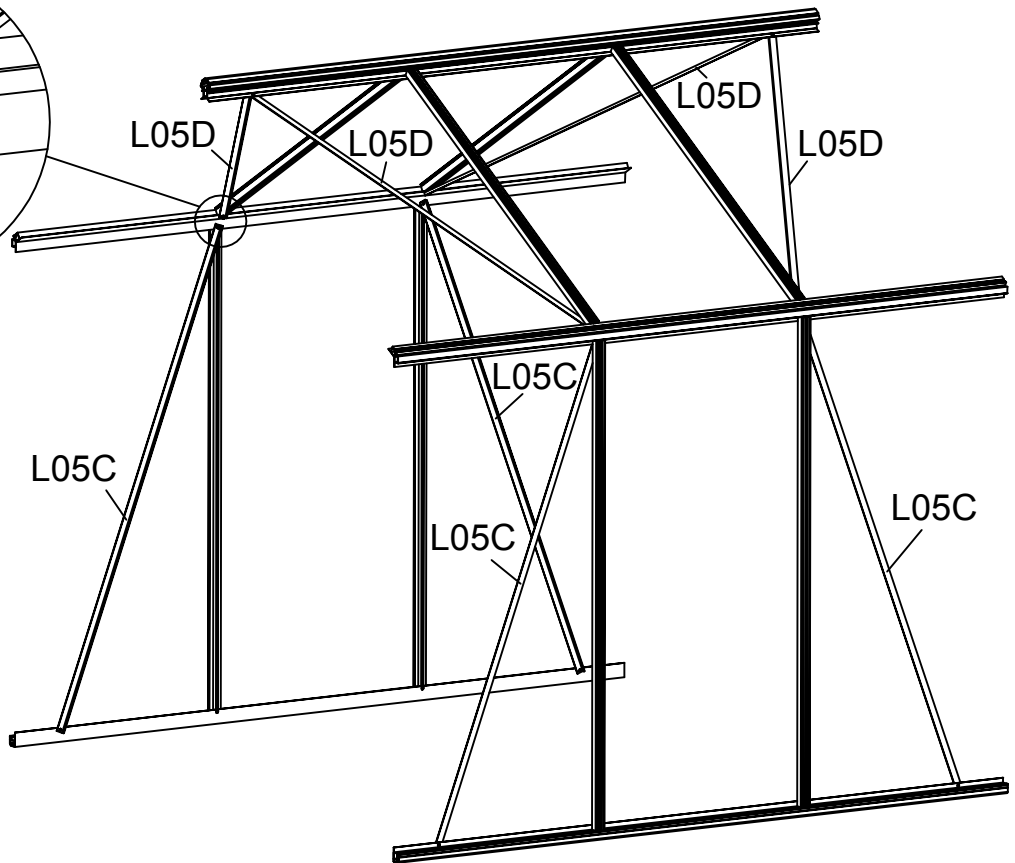
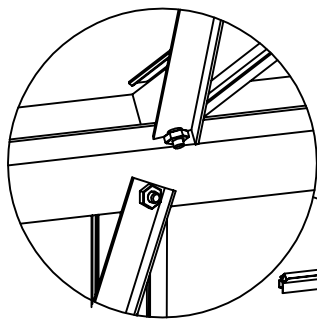
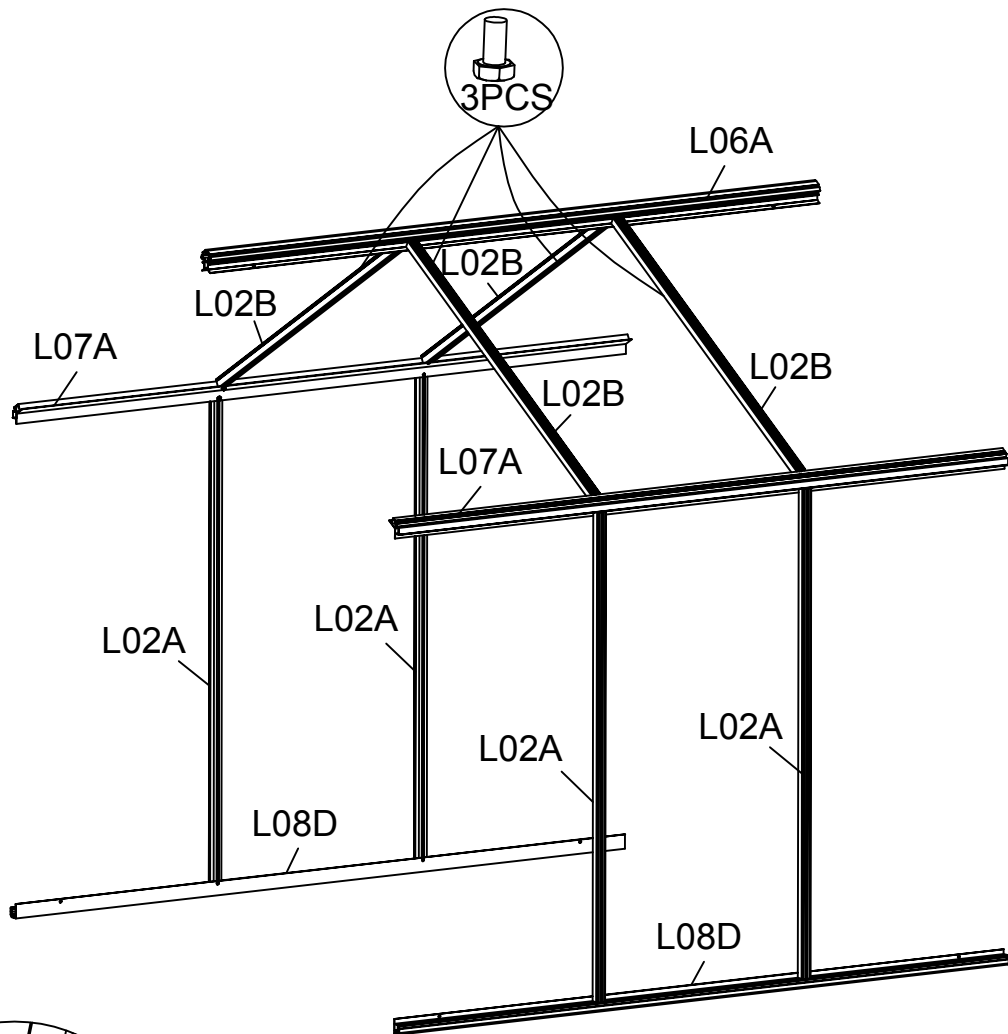

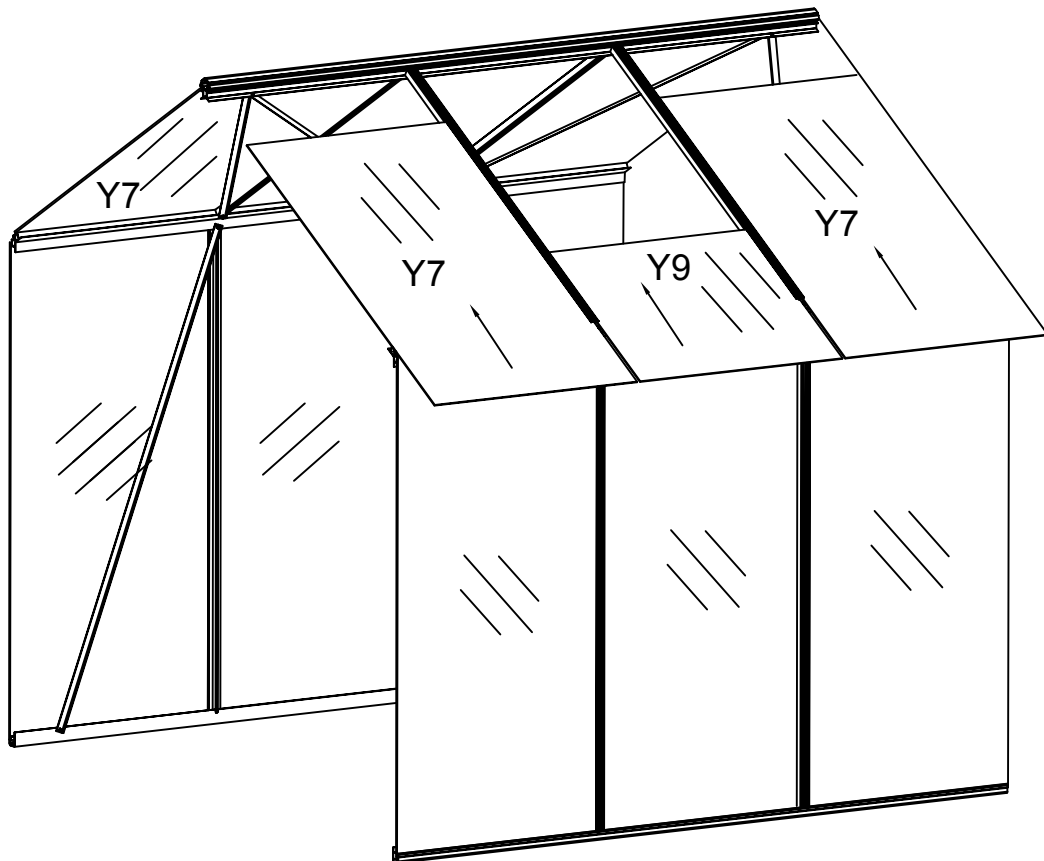
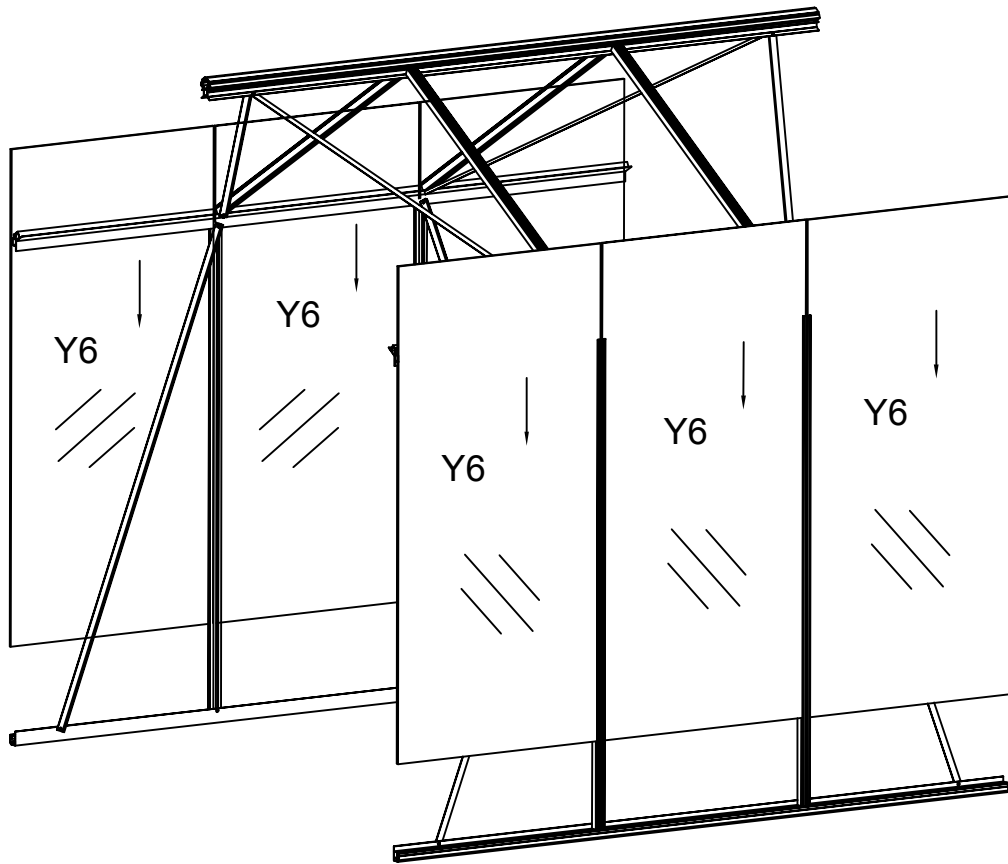

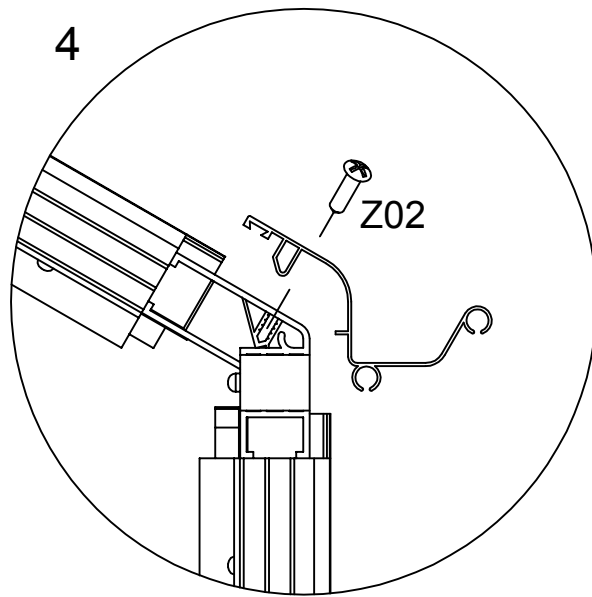
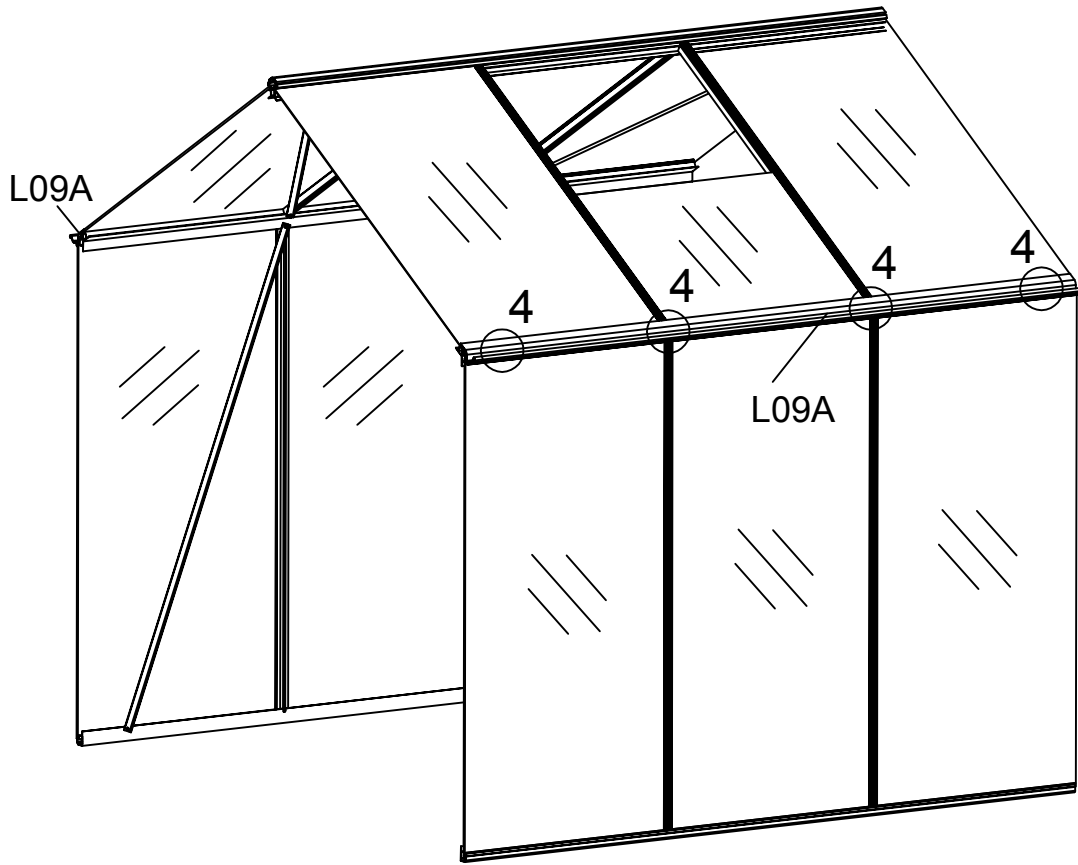

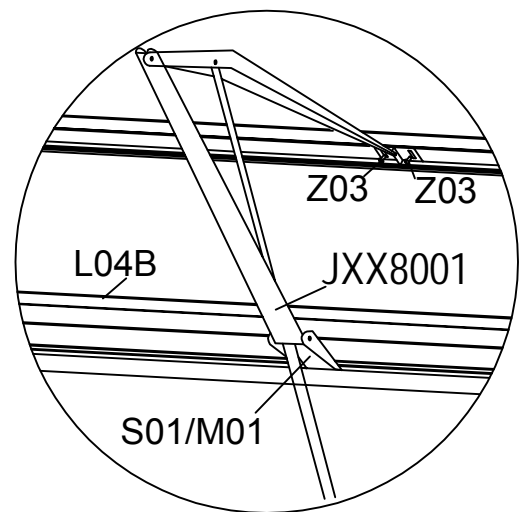
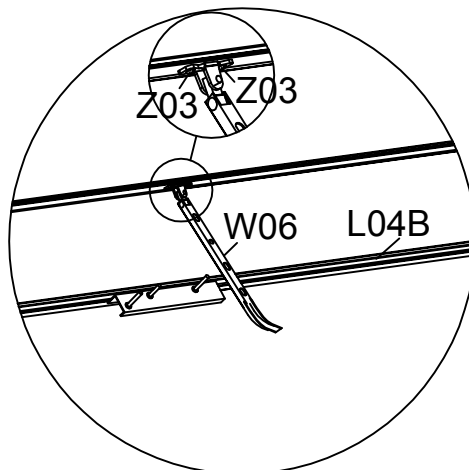
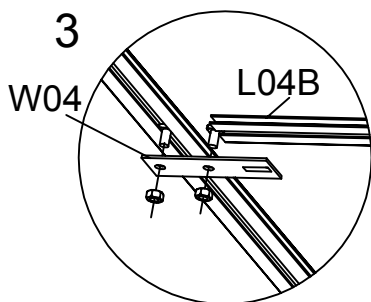
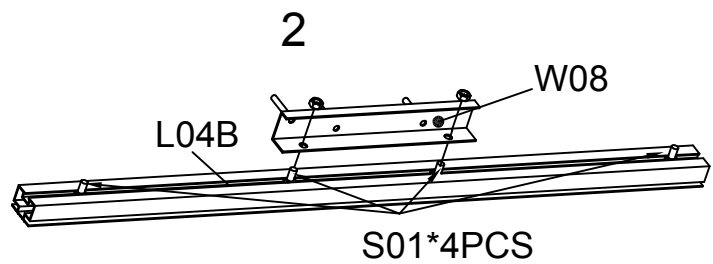
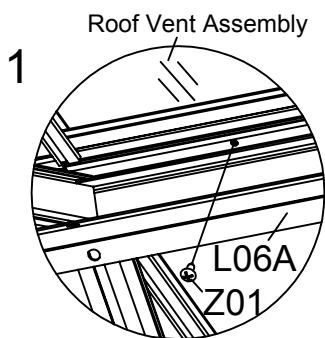
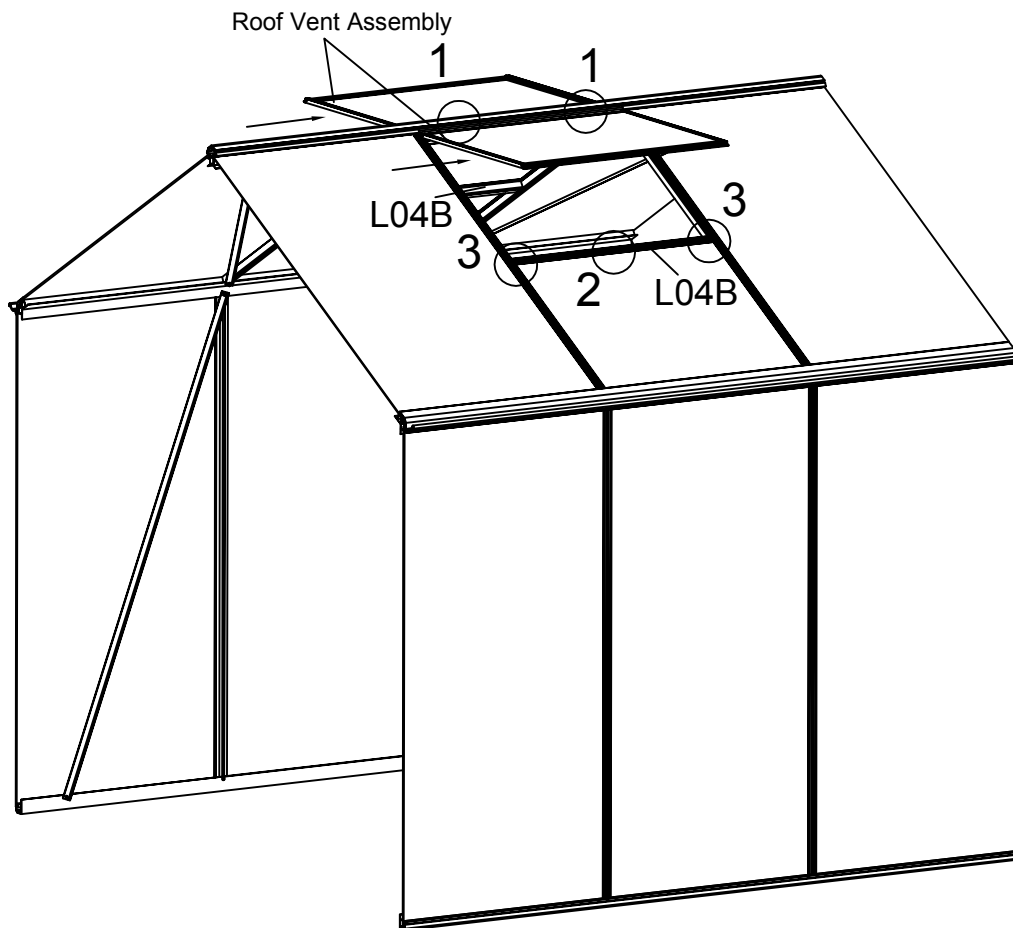

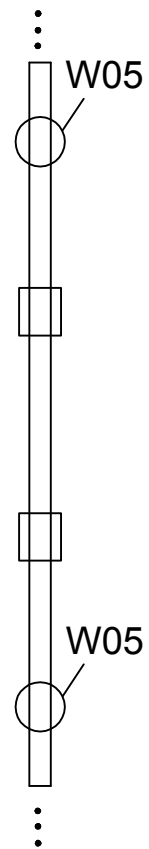
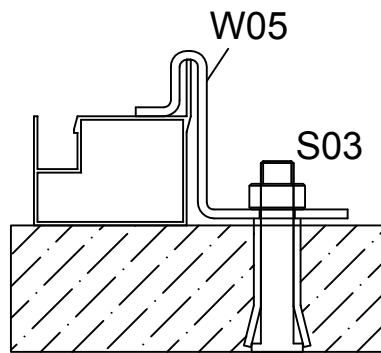
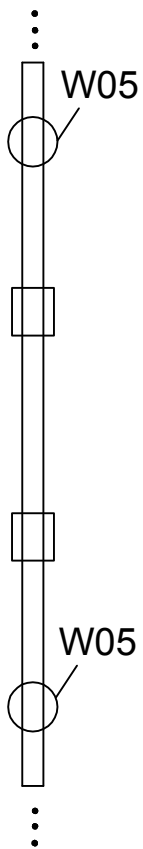



















PART	NO.	QTY.	PART	NO.	QTY.
	L10A	2		W02	2
	L10B	2		S01	8
	L10C	2		M01	8
	L08B	2		Z01	8
				C	2
				G	2
				H	1
				K	2
				W05	2
				S03	2
				J04	2
				J05	2
				J06	1

Middle Section Assembly Instruction

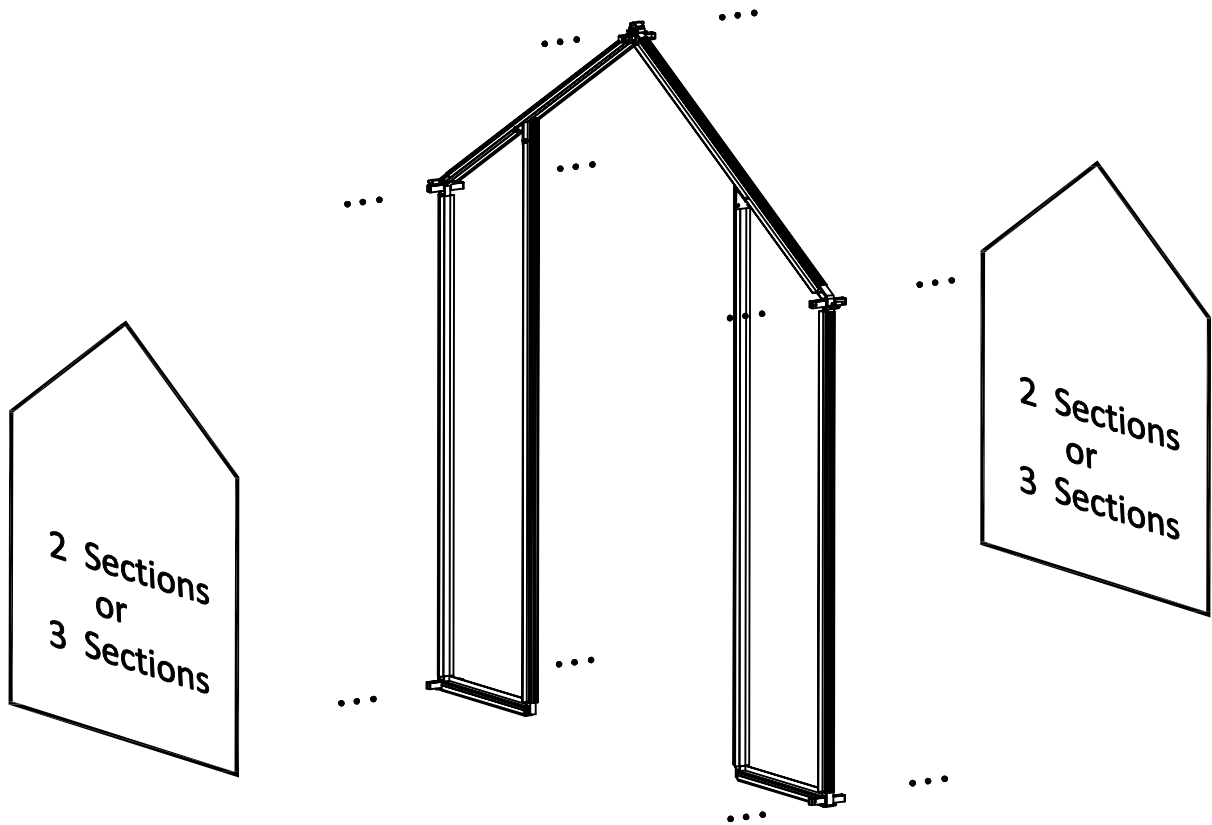

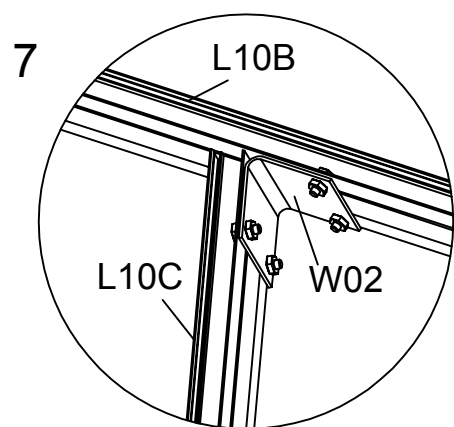
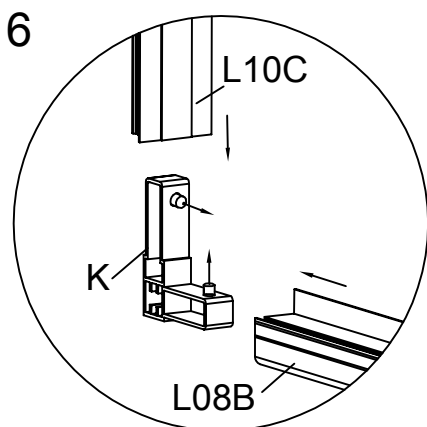
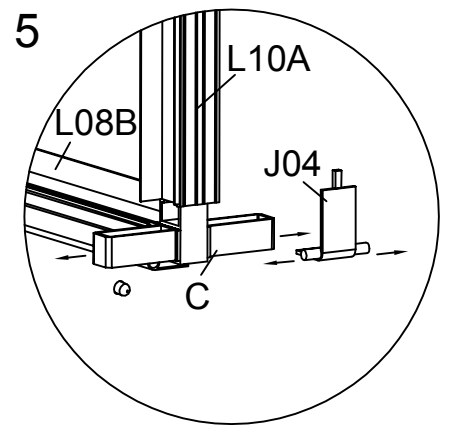
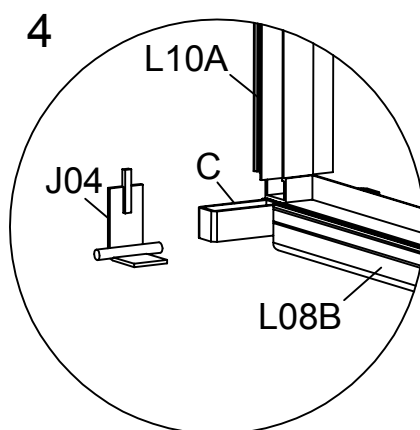
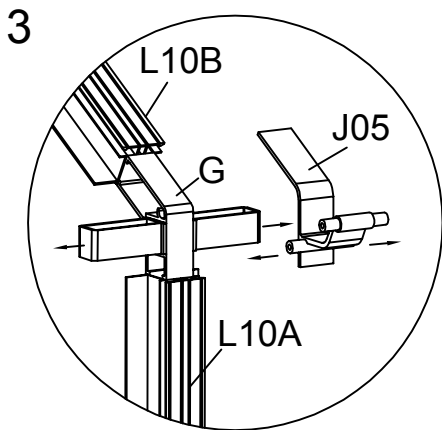
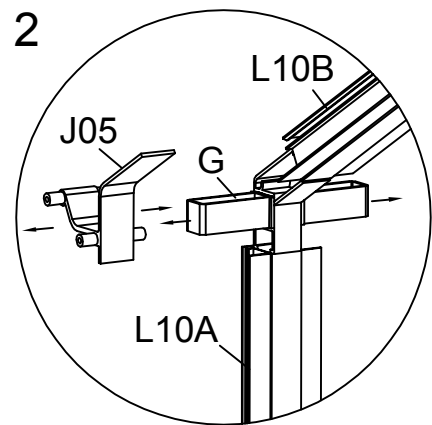
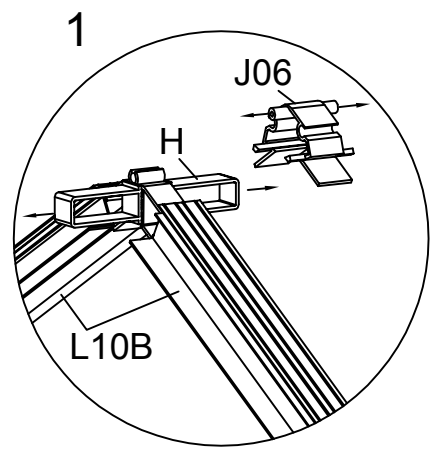
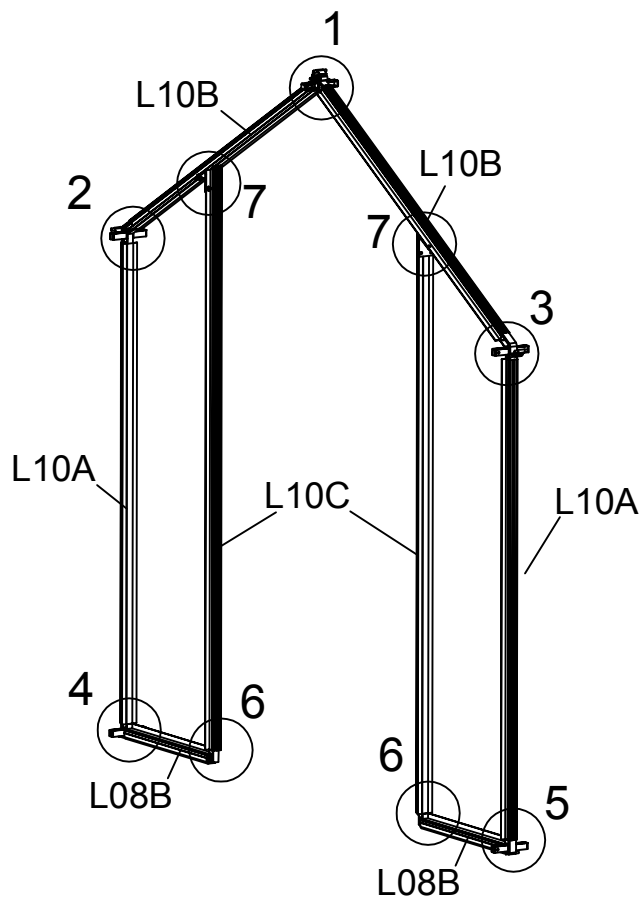

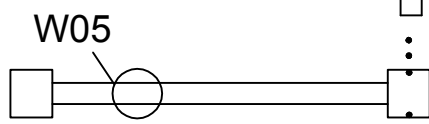
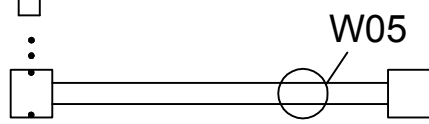
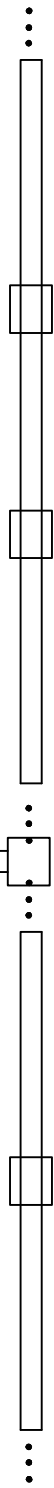
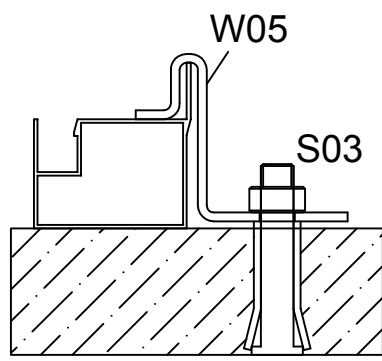
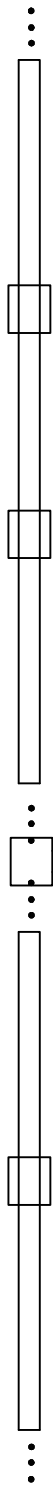

Example of JXX80305

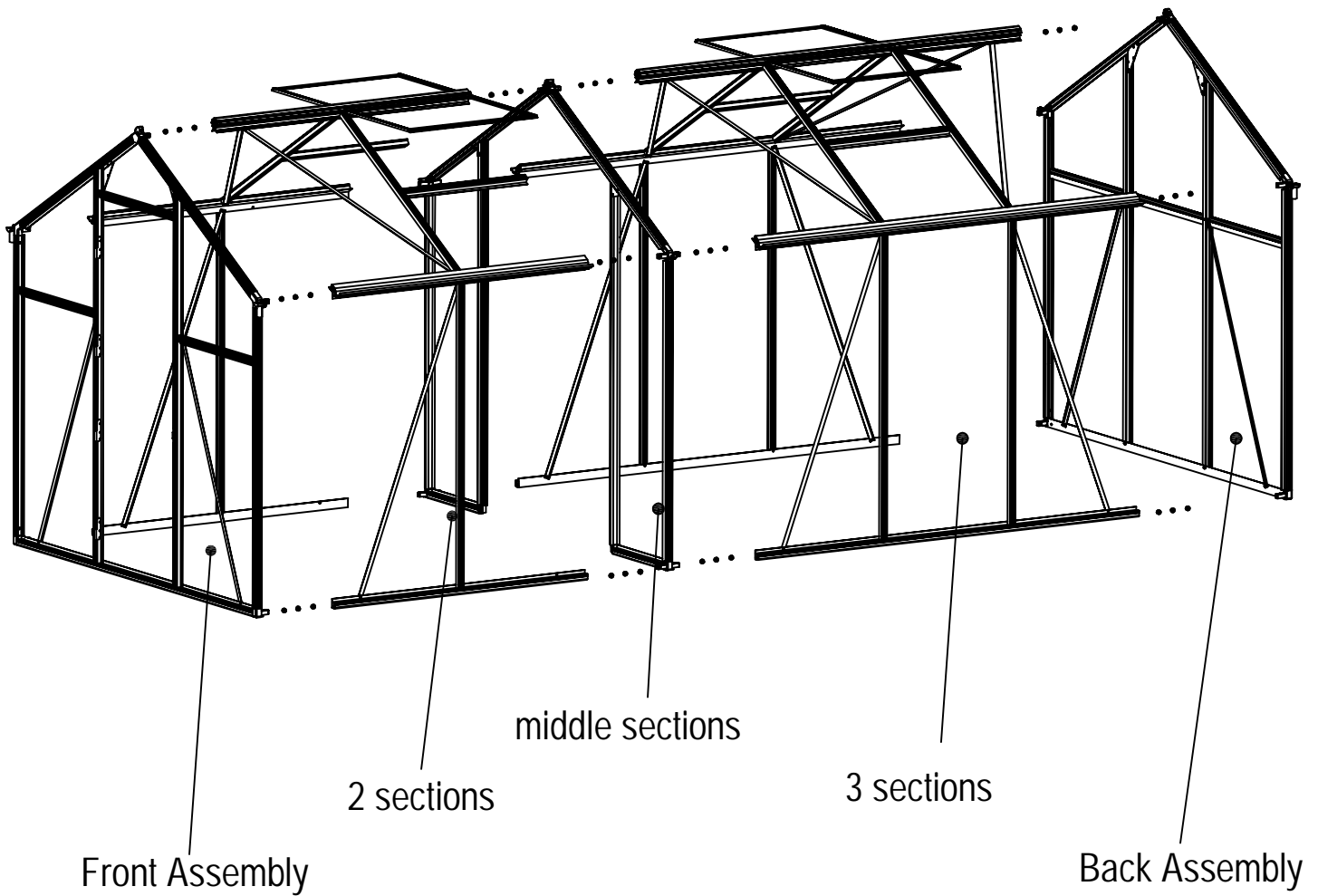

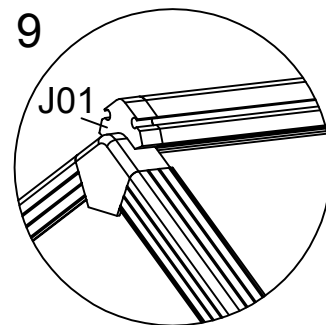
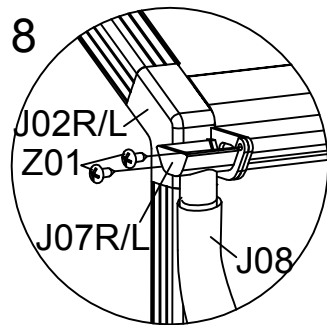
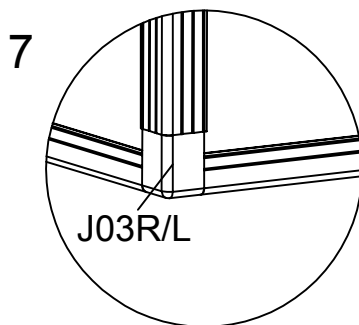
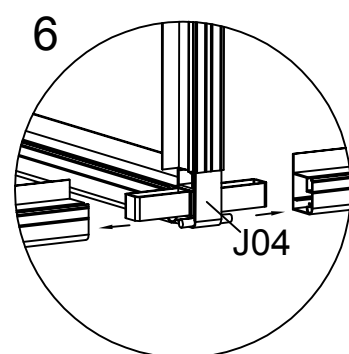
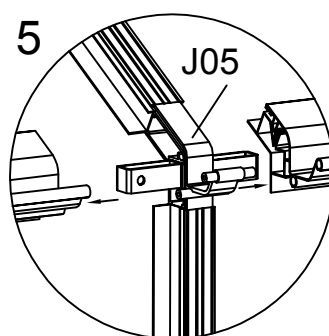
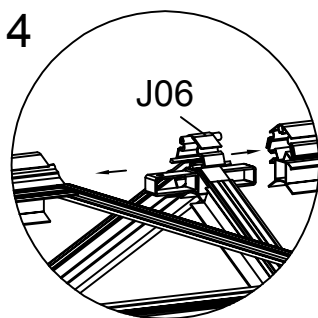
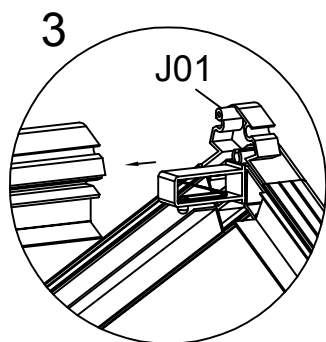
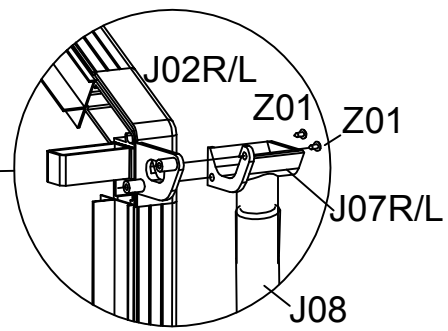
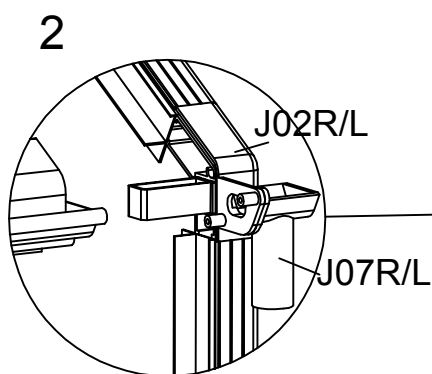
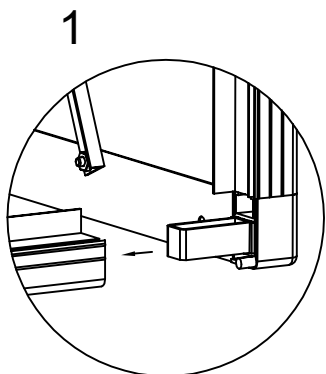
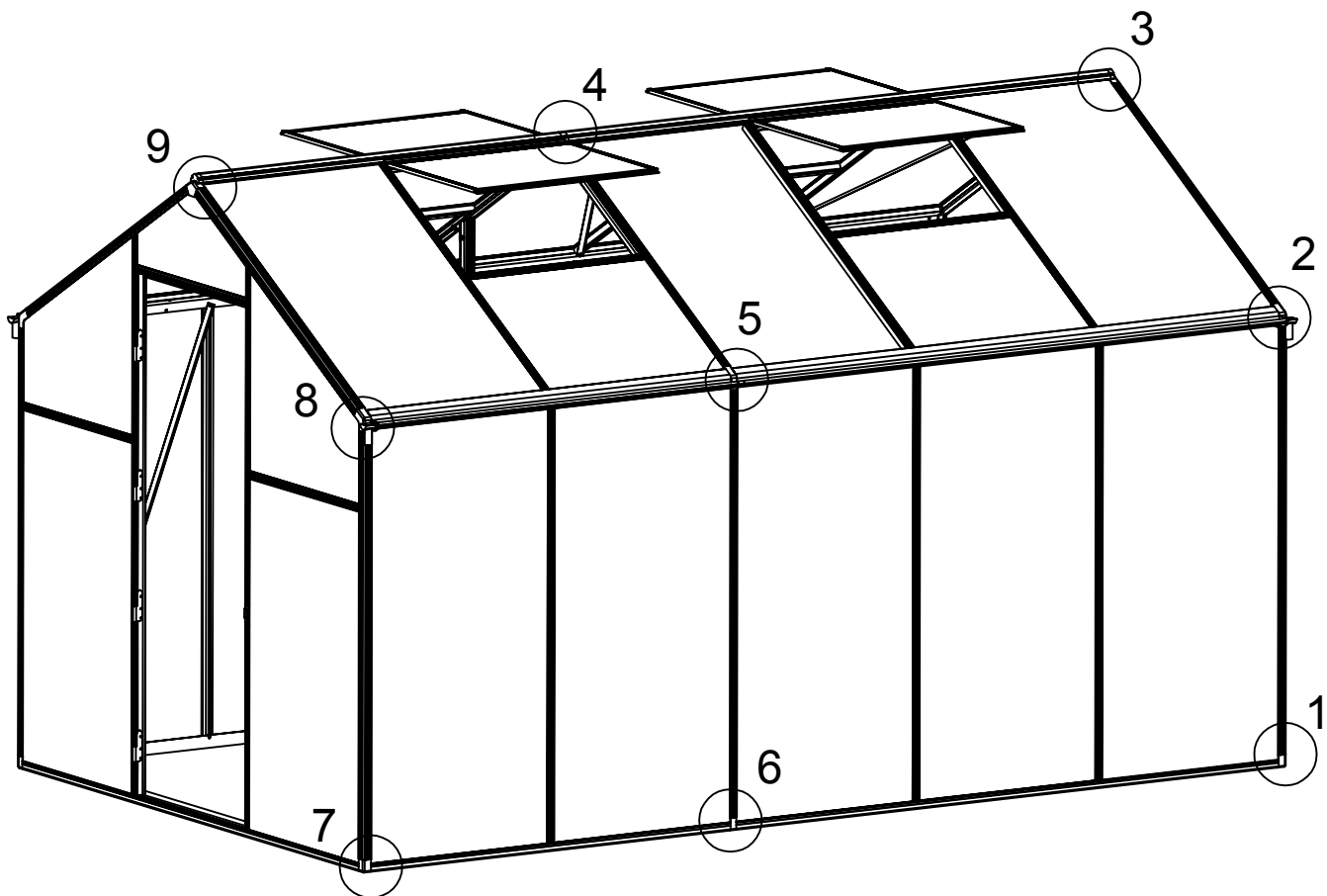

Door2 Assembly

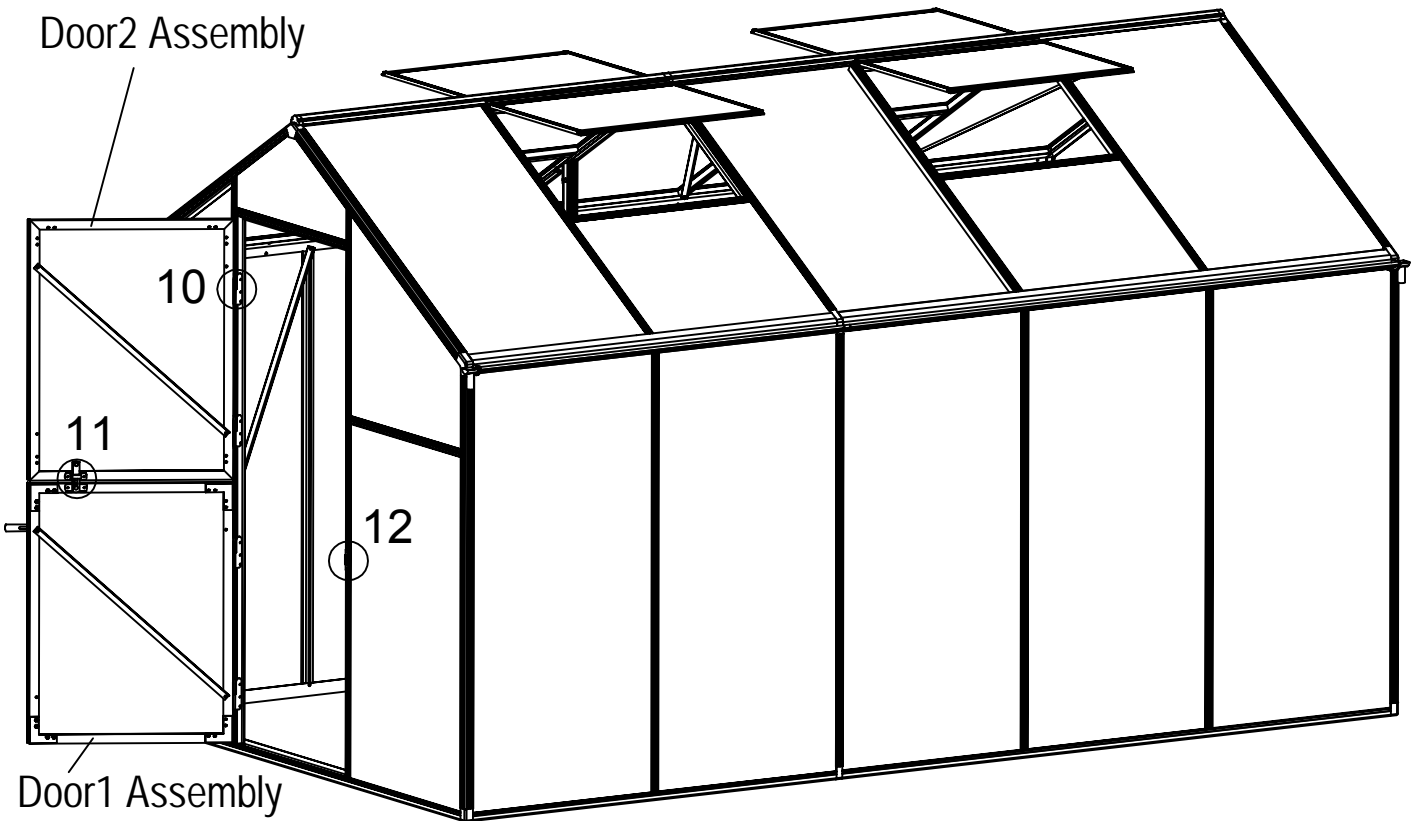

Door1 Assembly

10

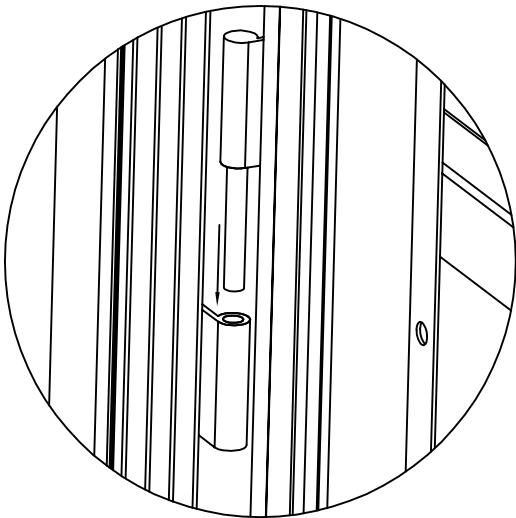

11

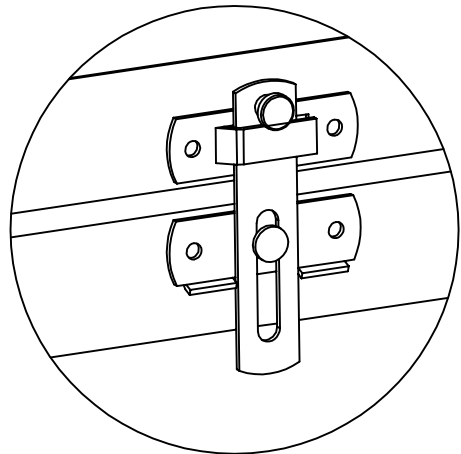

12

